

# Instruction Manual

## VDOT-DOP-AC240V-SCI Dual Output Module

### Before Installation

Please read these instructions carefully and keep for future reference.  
The information in this document is subject to change without notice.  
For updates please refer to our website.

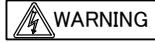

There is a danger of electric shock due to the presence of high voltage (AC250V). Never touch the terminals while the power is on. Make sure to turn off the high voltage AC power supply before commencing wiring work.

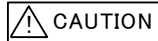

Do not use the products outside the rated power supply voltage range specified in the Specifications. It may cause a fire or damage to equipment.

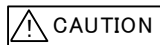

Do not disassemble, repair, or modify the products. It may cause a fire or electric shock.



Make sure to turn the power off before commencing any wiring work. Otherwise it may cause electric shock or damage to equipment.

**Note :** Follow the requirements for the installation of the product in accordance with the Specifications. Otherwise it may cause malfunction.

**Note :** Do not install the product in any location where oil, dust, iron powder, chemicals, or hydrogen sulphide may occur or affect the product. It may cause malfunction.

### This package contains the following items:

Main unit .....	1
Outer cover .....	1
Instruction Manual .....	1
Tapping screw .....	2
Pan head screw .....	2

### General Description

VDOT-DOP-AC240V-SCI Dual Output Module with Short Circuit Isolator is an addressable dual output module that provides two dry contacts. The contact rating is 4.8A at AC250V. The status of each dry contact is controlled by a control panel.

### General Operation

**Normal Standby condition:** The module receives polling from the control panel at the regular interval. Polling LED (green) flashes.

**Active condition:** When receiving a control signal from the control panel,

the relay output is activated, and Output LED (red) illuminates.

**Trouble condition:** If an overcurrent occurs because SLC (Signaling Line Circuit) is shorted, SCI LED (yellow) illuminates, and the module communicates to the control panel the short status.

### SCI (short circuit isolator) Function

The module has a built-in short circuit isolator. SCI circuit prevents entire loop failure in the event of a short between L+ and L- on the loop. If a short is detected between L+ and L-, the yellow LED is illuminated. The line between Lin- and Lout- is disconnected automatically to isolate the short circuit, and short circuit status is communicated to the control panel. Upon removal of the short condition, the module will automatically connect between Lin- and Lout- to restore the entire loop to the normal standby status.

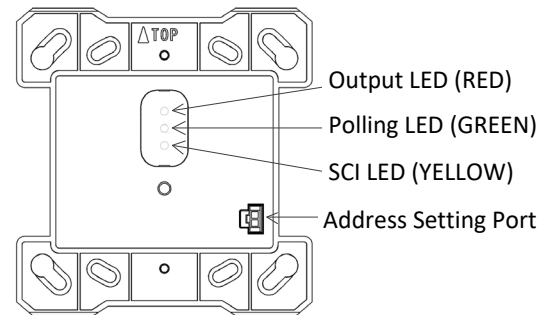

Figure 1

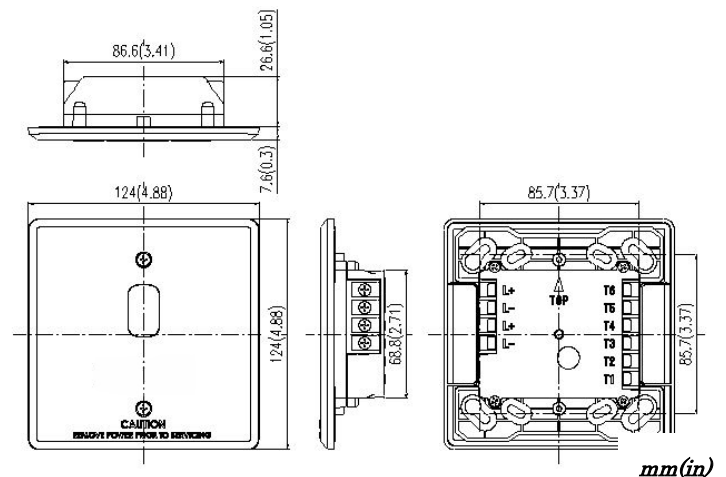

Figure 2

### Compatibility Requirement

To ensure proper operation, the module shall be connected to UL listed control panel series.

## Before Installing

Disconnect power to the control panel before installing the module. If the module is installed in an existing operational system, inform the operators and local authorities that the system will be temporarily out of service.

## Mounting

Make sure to use a metal UL Listed electrical box (4" square) to mount the module.

Secure the module to the box, as shown in Figure 3.

**Note:** The module must be mounted in a metal electrical box.

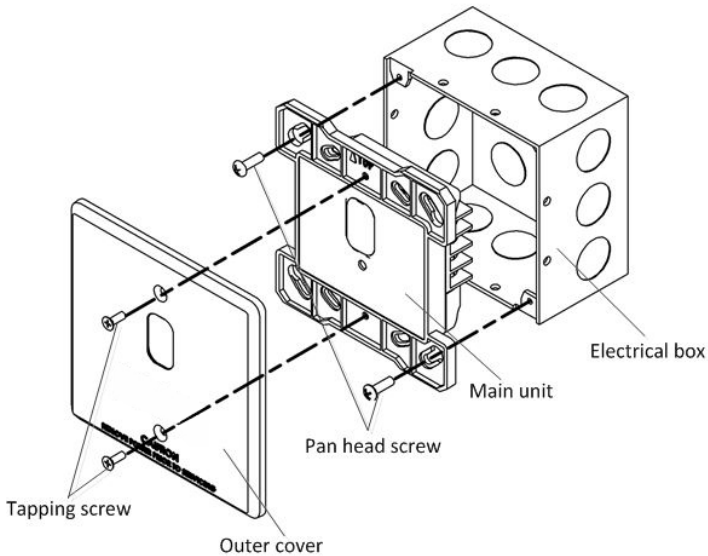

Figure 3

## Address Setting

Use VDOT-AD2 Programmer for setting the address of the module prior to installation. VDOT-DOP-AC240V-SCI has an address given at random from factory. Connect the Programmer with the address setting port to change the address to any of 1-254 (dec), with reference to the instruction manual of VDOT-AD2 Programmer. The address can be set regardless of whether power supply from the control panel is turned on or off. During setting address, the module does not respond to the control panel.

Set the address of module according to Job data.

## Wiring

All wiring must conform to applicable local codes, ordinances, and regulations.

Install module wiring in accordance with the appropriate wiring diagrams.



There is a danger of electric shock due to the presence of high voltage (AC250V). Never touch the terminals while the power is on. Make sure to turn off the high voltage AC power supply before commencing wiring work.

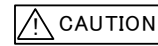

Use cable AWG12-22 for wiring. Do not connect different gauge cables at one terminal in order to prevent loosening. Use a fork terminal for crimping two cables.

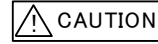

Do not connect cables in reverse polarity. Failure to connect the polarity correctly could result in damage to the module and/or other equipment.

Refer to the figure 4 for wiring.

**Note:** All wiring is power-limited and supervised.

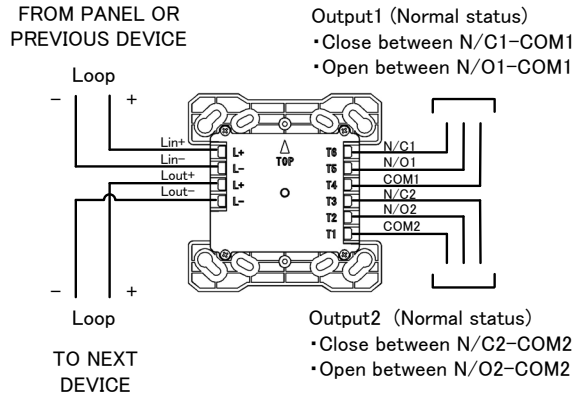

Figure 4

## Maintenance

Routine inspection: Ensure the module is secure and undamaged.

## Operation Test

The purpose of the Operational Test is to confirm the product's correct operation.

- 1) When carrying out site testing of the product, the control panel shall be set to "one-man-walk test mode" prior to the test.
- 2) Take any necessary precautions to limit the sounding of the alarm sounders/bells and any fire service summoning device.
- 3) Operate an active signal from the control panel to activate the relay output of the module, and confirm that the output LED (red) illuminates.

**Note:** If the test cannot be carried out as terminal wiring is connected, remove the wire connected to the dry contacts, and test between terminal N/C1, N/O1 and COM1 ( N/C2, N/O2 and COM2) to check the module. (When activated, the contact between N/C1 and COM1 (or between N/C2 and COM2) is open, and the contact between N/O1 and COM1 (or between N/O2 and COM2) is closed.)

- 4) After the module is brought into the active condition, reset the module. It may be necessary to allow a short time to elapse before the module is reset.

Confirm that the module goes back to the initial status after the module is reset. (In the normal status, the contact between N/C1 and COM1 (or between N/C2 and COM2) is closed, and the contact between N/O1 and COM1 (or between N/O2 and COM2) is open.

- 5) Short between terminal Lin+ (Lout+) and Lin- (Lout-), and the SCI LED (yellow) is illuminated. The short circuit isolator isolates the devices connected after the short-circuited area, which makes these devices have no response. Upon removal of the short condition, the area is automatically connected to go back to the normal standby status, and the SCI LED (yellow) turns off.

FOR WARRANTY SERVICE, RETURN TO:

ZETA ALARMS LIMITED

72-78 MORFA ROAD, SWANSEA, SA1 2EN

<http://www.zetaalarmsystems.com>

### Specifications

SLC Applied Voltage	Rated range 20 to 38VDC
SLC Current Consumption	Standby 0.6mA Activated 3.3mA (max)
SLC Line Impedance	Up to 50 ohms
Relay (Programmable)	Switching capacity AC250V/4.8A
SCI on Resistance	0.2 ohms (max)
SCI Fault Detection Threshold	10V (min)
SCI Isolation Current	22mA (max)
Visual Indicator (Status LED)	Polling LED (GREEN) Output LED (RED) SCI LED (YELLOW)
Ambient Installation Temperature	0°C to 49°C (32°F to 120°F)
Storage Temperature	-20°C to 60°C (-4°F to 140°F)
Max Relative Humidity	Up to 93% RH, non-condensing
Environment	Indoor dry use only
Max. quantity per loop	127 units
Terminal	Screw AWG12 to 22
Address Setting	VDOT-AD2 Address Programmer
Dimensions	124mm H x 124mm W x 34.5mm D (4.882" H x 4.882" W x 1.358" D) (4" square by 2 <sup>1</sup> / <sub>8</sub> " deep)
Weight	Approximately 172g (6.1oz)
Conformity	UL864

### Warranties

1.1 Zeta warrants to the customers that:

- (a) all products supplied hereunder will be of merchantable quality and will comply with any specification agreed between Zeta and customer.
- (b) it is not aware of any rights of any third party in the market which would or might render the sale of the products, or the use of any of the trade marks on or in products, or the use of any of the trade marks on or in relation to the products, unlawful.

1.2 In the event of any breach of the Zeta's warranty in Clause 1.1(a) whether by reason of defective materials, production faults or otherwise, Zeta's liability shall be limited to:

- (a) replacement of the products in question; or
- (b) at the Zeta's option, repayment of the price where this had been paid.
- And the warranty period is three (3) years from the shipment from Zeta's factory.

1.3 Notwithstanding anything to the contrary in this warranty terms, Zeta shall not be liable to the customer by reason of any representation or implied warranty, condition or other term or any duty at common law, or under the express terms of this warranty terms, for any consequential loss or damage whether for loss of profit or otherwise and whether occasioned by the negligence of Zeta or its employees or agents or otherwise, arising out of or in connection with any act or omission of Zeta relating to Zeta or supply of the products, their use by any customer.

1.4 Customer shall indemnify Zeta against all loss, damages, liabilities, costs and expenses which Zeta may suffer or incur as a result of or in connection with any breach by customer of this warranties terms or any laws or regulations of any jurisdiction or any rules of any governing authorities.