

# Instruction Manual

## VDOT-DIP-SCI Dual Input Module

### Before Installation

Please read these instructions carefully and keep for future reference.  
The information in this document is subject to change without notice.  
For updates please refer to our website.



Do not use the products outside the rated power supply voltage range specified in the Specifications. It may cause a fire or damage to equipment.



Do not disassemble, repair, or modify the products. It may cause a fire or electric shock.

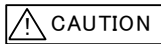

Make sure to turn the power off before commencing any wiring work. Otherwise it may cause electric shock or damage to equipment.

**Note :** Follow the requirements for the installation of the product in accordance with the Specifications. Otherwise it may cause malfunction.

**Note :** Do not install the product in any location where oil, dust, iron powder, chemicals, or hydrogen sulphide may occur or affect the product. It may cause malfunction.

### This package contains the following items:

Main unit .....	1
Outer cover .....	1
Instruction Manual .....	1
Tapping screw .....	2
Pan head screw .....	2
EOL register (VDOT-RE-10k) .....	2

### General Description

VDOT-DIP-SCI Dual Input Module with Short Circuit Isolator is intended for use in addressable two wire systems. The module monitors and transmits the status (normal, open, short, or active) of devices equipped with NC/NO dry contacts to a control panel. The initiating device circuit (IDC) can be wired on Class A or Class B.

**Note:** Any conventional detector cannot be connected with the module.

### General Operation

**Normal standby condition:** The module receives polling from the control panel at the regular interval. Polling LED (green) flashes.

**Active condition:** When an external input is activated, Input LED (red) illuminates, and the module communicates to the control panel the active status.

**Trouble condition:** If an overcurrent occurs because SLC (Signaling Line Circuit) is shorted, SCI LED (yellow) illuminates, and the module communicates to the control panel the short status. The module also communicates to the control panel the open/short status of IDC, depending on the Subtype Setting described below.

### SCI (Short Circuit Isolator) Function

The module has a built-in short circuit isolator. SCI circuit prevents entire loop failure in the event of a short between L+ and L- on the loop. If a short is detected between L+ and L-, the yellow LED indicator is illuminated. The line between Lin- and Lout- is disconnected automatically to isolate the short circuit, and short circuit status is communicated to the control panel. Upon removal of the short condition, the module will automatically connect between Lin- and Lout- to restore the entire loop to the normal standby status.

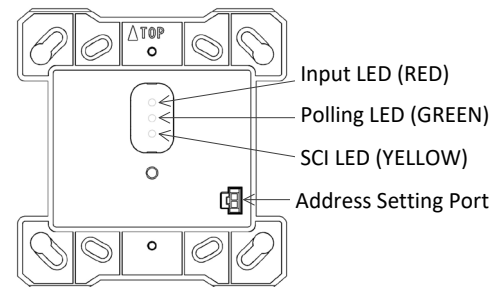

Figure 1

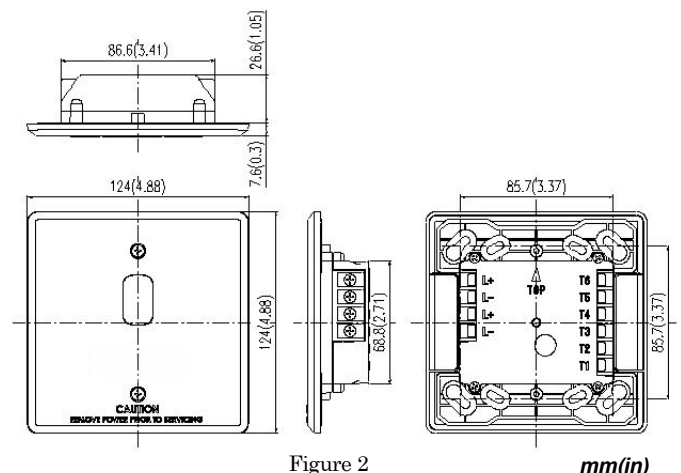

Figure 2

mm(in)

**Compatibility Requirement**

To ensure proper operation, the module shall be connected to UL listed Velocity MMP control panel series.

**Before Installing**

Disconnect power to the control panel before installing the module. If the module is installed in an existing operational system, inform the operators and local authorities that the system will be temporarily out of service.

**Mounting**

Mount the module directly to 4" square electrical box (UL Listed). Secure the module to the electrical box, as shown in Figure 3.

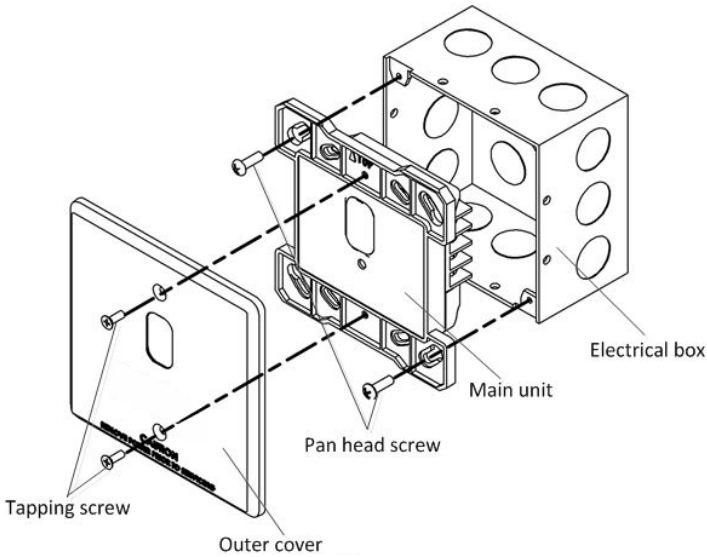

Figure 3

**Setting**

**• Address Setting**

Use VDOT-AD2 Programmer for setting the address of the module prior to installation. VDOT-DIP-SCI has an address given at random from factory. Connect the Programmer with the address setting port to change the address to any of 1-254 (dec), with reference to the instruction manual of VDOT-AD2 Programmer. The address can be set regardless of whether power supply from the control panel is turned on or off. During setting address, the module does not respond to the control panel.

Set the address of module according to Job data.

**• Subtype Setting**

Set the subtype depending on the wiring configuration as below. The subtype is to be set through the Configurator for the control panel.

Sub Type	Input Method	Open -circuit Detection	Short -circuit Detection	Class (Style)	Interrupt
1	Normally	Yes	No	Class B	Disabled
2					Enabled
3	Open	Yes	No	Class A	Disabled
4					Enabled
5	Normally	No	Yes	Class B	Disabled
6	Close	No	Yes		Enabled
7	Normally	Yes	Yes	Class B	Disabled
8					Enabled
9	Open	Yes	Yes	Class A	Disabled
10					Enabled

When interrupt is enabled, it allows a high priority communication to the control panel. The consumption current increases with this setting.

**Note:** Applicable subtype setting differs depending on control panels.

Subtype 1 to 10 can be used with the control panel complying with UL864 9<sup>th</sup> edition.

Subtype 7 to 10 can be used with the control panel complying with UL864 10<sup>th</sup> edition.

Please contact Velocity customer service for any required details.

**Wiring**

All wiring must conform to applicable local codes, ordinances, and regulations.

Install module wiring in accordance with the appropriate wiring diagrams.

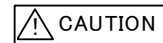

Use cable AWG12-22 for wiring. Do not connect different gauge cables at one terminal in order to prevent loosening. Use a fork terminal for crimping two cables.

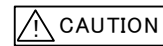

Do not connect cables in reverse polarity. Failure to connect the polarity correctly could result in damage to the module and/or other equipment.

**Note:** All wiring is power-limited and supervised.

**Class B (Short circuit detection is not available)**

EOL (10k ohm) is connected between A+ (B+) and A- (B-) in VDOT-DIP-SCI.

Dry contact switches (input switches) are OFF.

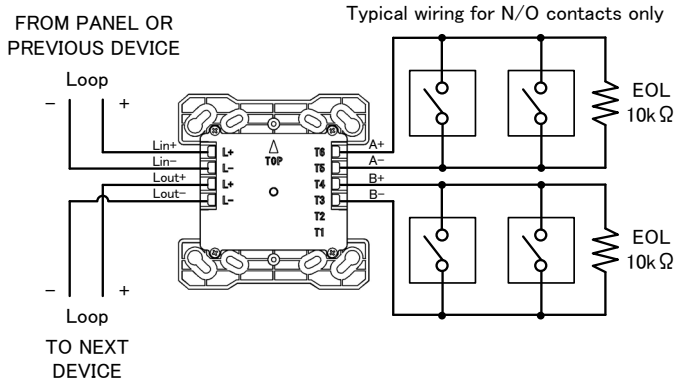

Figure 4

**Class A (Short circuit detection is not available)**

It is a status that dry contact switches connected between A+ (B+) and A- (B-) in VDOT-DIP-SCI are OFF.

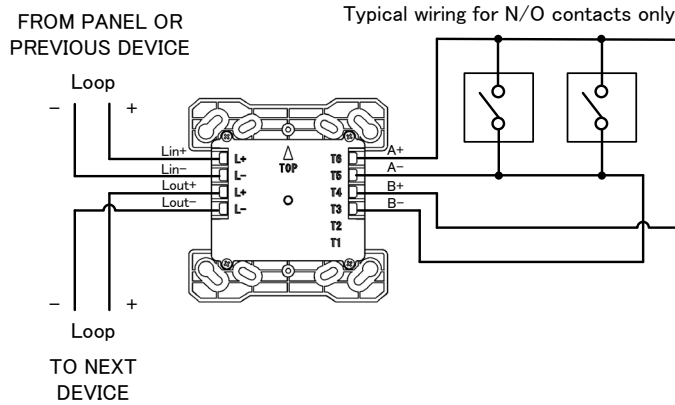

Figure 5

**Class B (Short circuit detection is available)**

EOL (10k ohm) is connected between A+ (B+) and A- (B-) in VDOT-DIP-SCI.

Dry contact switches are OFF.

\*Two external inputs can be connected to one input line.

\*Resistor of 2.2k ohms (VDOT-RE-2.2k) is an option and not included in this product.

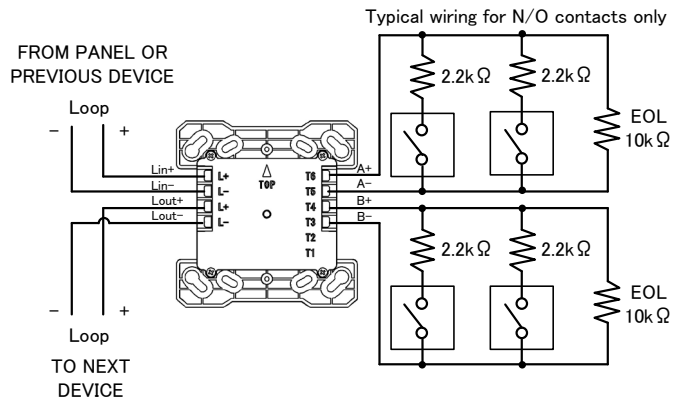

Figure 6

**Class A (Short circuit detection is available)**

It is a status that dry contact switches connected between A+ (B+) and A- (B-) in VDOT-DIP-SCI are OFF.

\*Two external inputs can be connected to the input line.

\*Resistor of 2.2k ohms (VDOT-RE-2.2k) is an option and not included in this product.

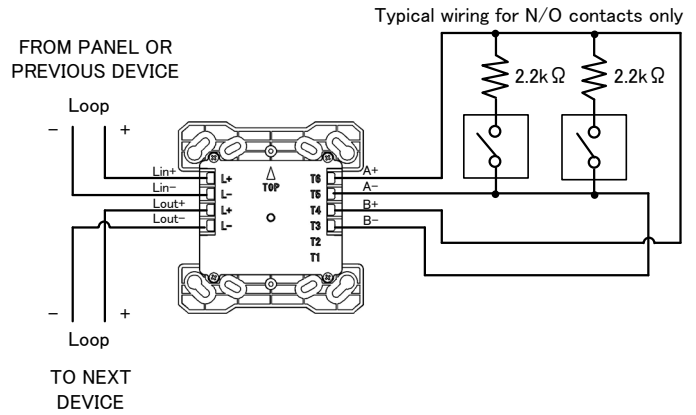

Figure 7

**Normally Close Class B**

A dry contact switch and EOL (10k ohm) are connected in series between A+ (B+) and A- (B-) in VDOT-DIP-SCI.

Dry contact switches are ON.

\*Only one external input can be connected to one input line.

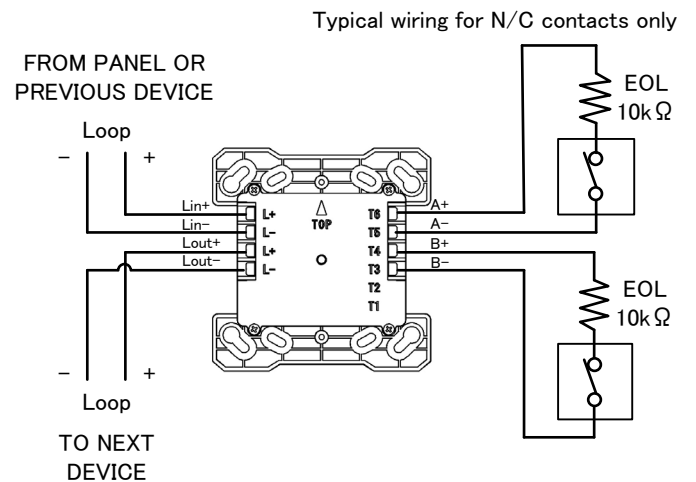

Figure 8

## Maintenance

Routine inspection: Ensure the module is secure and undamaged.

## Operation Test

The purpose of the Operational Test is to confirm the product's correct operation.

- 1) When carrying out site testing of the product, the control panel shall be set to "one-man-walk test mode" prior to the test.
- 2) Take any necessary precautions to limit the sounding of the alarm sounders/bells and any fire service summoning device.
- 3) Turn on the external inputs connected to the module, and confirm that the module is in active condition and the input LED (red) illuminates. Confirm that an active signal is transmitted to the control panel.

**Note:** If the test cannot be carried out through the external inputs, test the area between terminal A+ and A- (or B+ and B-) to check the module. (In accordance with the subtype setting, set the status either 0Ω short (for subtype 1-4), 2.2kΩ short (for subtype 7-9), or open (for subtype 5-6).)

- 4) After the external inputs have brought the module into the active condition, reset the external inputs. Confirm that the module goes back to the initial status after the external inputs are reset.
- 5) If subtype is set as 1-4, or 7-10, open between terminal A+ and A- (or B+ and B-) and confirm that the control panel detects the open circuit. If subtype is set as 5-10, short between terminal A+ and A- (or B+ and B-) and confirm that the control panel detects the short circuit.
- 6) Short between terminal Lin+ (Lout+) and Lin- (Lout-), and the SCI LED (yellow) illuminates. The short circuit isolator isolates the devices connected after the short-circuited area, which makes these devices have no response. Upon removal of the short condition, the area is automatically connected to go back to the normal standby status, and the SCI LED (yellow) turns off.

FOR WARRANTY SERVICE, RETURN TO:

ZETA ALARMS LIMITED

72-78 MORFA ROAD, SWANSEA, SA1 2EN. UK

<http://www.zetaalarmsystems.com>

## Specifications

SLC Applied Voltage	Rated range 20 to 38VDC
SLC Current Consumption	Standby 3.0mA Activated 16.9mA (max)
SLC Line Impedance	Up to 50 ohms
Number of IDC Circuits	1 x Class A or 2 x Class B
IDC Circuit Rating	15VDC, 2.2k ohms, 6.8mA (max)
IDC Line Impedance	Up to 50 ohms
EOL Device	VDOT-RE-10k (10k ohms, 1/4W), Class B only 2.2k ohms EOL required for each dry contact switch in subtype setting 7,8,9,and 10
SCI on Resistance	0.2 ohms (max)
SCI Fault Detection Threshold	10V (min)
SCI Isolation Current	22mA (max)
Visual Indicator (Status LED)	Polling LED (GREEN) Input LED (RED) SCI LED (YELLOW)
Ambient Installation Temperature	0°C to 49°C (32°F to 120°F)
Storage Temperature	-20°C to 60°C (-4°F to 140°F)
Max Relative Humidity	Up to 93% RH, non-condensing
Environment	Indoor dry use only
Max. number of units per loop	127 units
Terminal	Screw AWG12 to 22
Address Setting	VDOT-AD2 Address Programmer
Dimensions	124mm H x 124mm W x 34.5mm D (4.882" H x 4.882" W x 1.358" D) (Mount to a 4" square by 2 1/8" deep box)
Weight	Approximately 153g (5.4oz)
Conformity	UL864

## **Warranties**

1.1 Zeta warrants to the customers that:

- (a) all products supplied hereunder will be of merchantable quality and will comply with any specification agreed between Zeta and customer.
- (b) it is not aware of any rights of any third party in the market which would or might render the sale of the products, or the use of any of the trade marks on or in products, or the use of any of the trade marks on or in relation to the products, unlawful.

1.2 In the event of any breach of the Zeta's warranty in Clause 1.1(a) whether by reason of defective materials, production faults or otherwise, Zeta's liability shall be limited to:

- (a) replacement of the products in question; or
  - (b) at the Zeta's option, repayment of the price where this had been paid.
- And the warranty period is three (3) years from the shipment from Zeta's factory.

1.3 Notwithstanding anything to the contrary in this warranty terms, Zeta shall not be liable to the customer by reason of any representation or implied warranty, condition or other term or any duty at common law, or under the express terms of this warranty terms, for any consequential loss or damage whether for loss of profit or otherwise and whether occasioned by the negligence of Zeta or its employees or agents or otherwise, arising out of or in connection with any act or omission of Zeta relating to Zeta or supply of the products, their use by any customer.

1.4 Customer shall indemnify Zeta against all loss, damages, liabilities, costs and expenses which Zeta may suffer or incur as a result of or in connection with any breach by customer of this warranties terms or any laws or regulations of any jurisdiction or any rules of any governing authorities.