

Dry Barrel Fire Hydrant

Model: MH-1510FA/MH-1510A

Fire Hydrant

Model: MH-1510FA/MH-1510A

Technical Features

- Nominal Pressure: 250PSI
- Design Standard: AWWA C502
- Inlet flange size: 6" (DN150), Main Valve size: 133.4 mm / 5-1/4"
- One pumper nozzle: 4.5-4NH thread. Two hose nozzles, 2.5-7.5NH threads
Other kinds of threads are available
- Mechanical connector: AWWA / ANSI C153 / A21.536, Model No.: MH-1510A
- Flange connector: ASME B16.5 CLASS 150/DIN 2501 PN16, Model No.: MH-1510FA
- Painting Details: Red Polyurethane paint & Bitumen Black or painting upon request
- Note: Each hydrant is supplied with a hydrant wrench
- Approvals: UL 246 Listed, FM 1510 Approved

Installation

- Hydrants should be handled with care to avoid damage. It is recommended to keep hydrants closed until use
- If the hydrant is not to be used straight away then it is recommended to coat threads and other machined parts with anti-rust oil and the hydrant should be stored in a dry and ventilated area. For long-term storage, the hydrant should be checked regularly
- Before installation of hydrants, the connection should be free from dirt or other matter
- The positioning of the hydrant should be in accordance with local requirements. Ideally the pumper should face the street and all connections should be away from any obstruction to connecting hoses
- The inlet elbow should be placed on a solid surface and if possible brace the side opposite the incoming flow to reduce reaction stresses
- The underground parts of the hydrant should be surrounded with coarse gravel for support and drainage
- After the hydrant has been installed and tested, it is recommended to fully flush the hydrant before closing for service. Before replacing the nozzle caps, it is recommended to check for correct drainage of the hydrant on closing of the valve. This can be achieved by placing a hand over the nozzle opening, a suction should be felt

Operation

- Unscrew the nozzle caps and connect hoses
- Open the hydrant using the hydrant key (included) to the fully open position by turning the operation nut in an anti-clockwise direction. Do not force the hydrant to open further past the fully open position. Note that the hydrant valve is not intended to control the flow, it should be used in either the fully open or fully closed position
To control flow, a pressure/flow control valve should be fitted to the nozzle outlets on the hydrant
- To close, turn the operation nut into a clockwise direction again, do not over tighten



3D Pictures

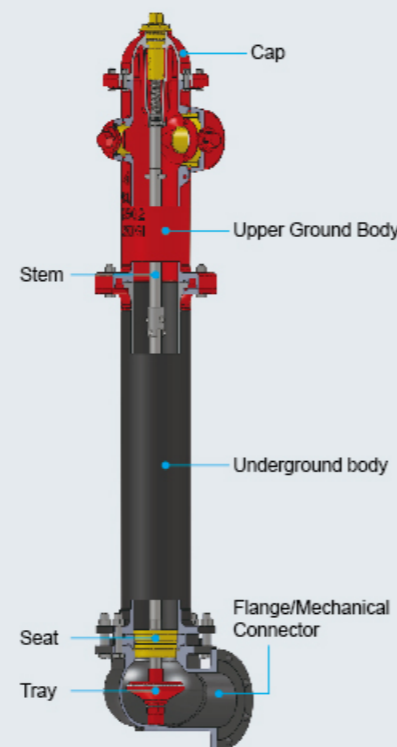

Maintenance

- Carry out a visual inspection for signs of significant corrosion which may impair performance
- Where possible, carry out leakage tests by opening one of the nozzle caps slightly and then open the hydrant valve
Once the air has escaped, tighten the hose cap and check for leaks
- Close hydrant and remove one nozzle cap so that the drainage can be checked
- Flush the hydrant
- Clean and lubricate all nozzle threads
- Clean the exterior of the hydrant and repaint if required

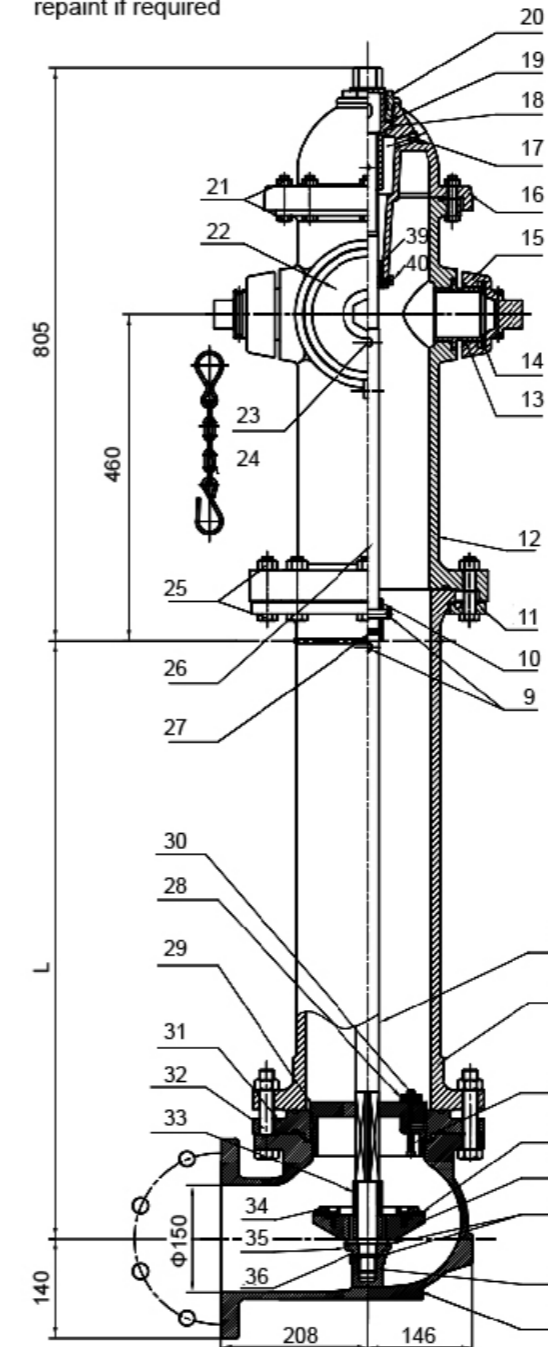

Buried Dimensions

L (mm)	3'6"	4'	4'6"	5'	5'6"	6'	6'6"	7'
	1063	1215	1368	1520	1673	1825	1978	2130

Material List

NO.	Name	Material
1	Flange Connector Or Mechanical Connector	Ductile Iron
2	Locking Nut	Ductile Iron
3	Connecting Rod	Steel 1045
4	Locking Nut Gasket	EPDM
5	Tray	Ductile Iron
6	Sealed Rubber Sheet	EPDM
7	Drain Hole Spring	316 Stainless Steel
8	Connecting Cylinder	Ductile Iron
9	Perforated Cylindrical Pin	Steel 1045
10	Connecting Rod Sleeve	Steel 1045
11	Clamp For Connection Tube	Ductile Iron
12	Main Body On Ground	Ductile Iron
13	65 Connector	C95400
14	65 Cover Gasket	EPDM
15	65 Cover	Ductile Iron
16	Upper End Cover	Ductile Iron
17	Thread Plug	C95400
18	Screw Stem Nut	C95400
19	Screw Nut Gasket	C95400
20	Screw Nut Seat	C95400
21	Bolt,nut	Steel 1035
22	100 Cover	Ductile Iron
23	Cylindrical Pin	Steel 1045
24	Cover Chain	Gr.B, ASTM A283-B
25	Bolt,nut	Steel 1035
26	Screw Stem	Steel 1045
27	Cushion Rubber	EPDM
28	Drain Hole Cover	C95400+EPDM
29	Seat	C95400
30	Bolt,nut	316 Stainless Steel
31	Seat Fixing Plate	Ductile Iron
32	Bolt,nut	Steel 1035
33	Annular Tubes	Steel 1045
34	Platen	Ductile Iron
35	Locking Nut Seat	Ductile Iron
36	Check Turn Gasket	Gr.B
37	100 Connector	C95400
38	100 Cover Gasket	EPDM
39	Screw Stem Bushing	316 Stainless Steel
40	Bolt	316 Stainless Steel