

Installation Instructions

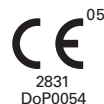

EN54-3:2001+A1:2002+A2:2006

Specification

Type	Nominal Voltage	Voltage Range	Current	Sound Pattern	*SPL @nominal voltage (@900 to front face)	EN54-3 SPL @28V DC dB(A) (see notes)
F/012	12VDC*	9-15VDC*	55-65mA	Bell Ring sound	95dB(A)	N/A *
F Bell FB/24	24VDC	18-30VDC	25-35mA	Bell Ring sound	95dB(A)	95dB(A)
F/230	230VAC*	200-250V*	20-30mA	Bell Ring sound	95dB(A)	N/A *

Note: Note: specifications marked with an * have **NOT** been verified to be compliant with EN54-3

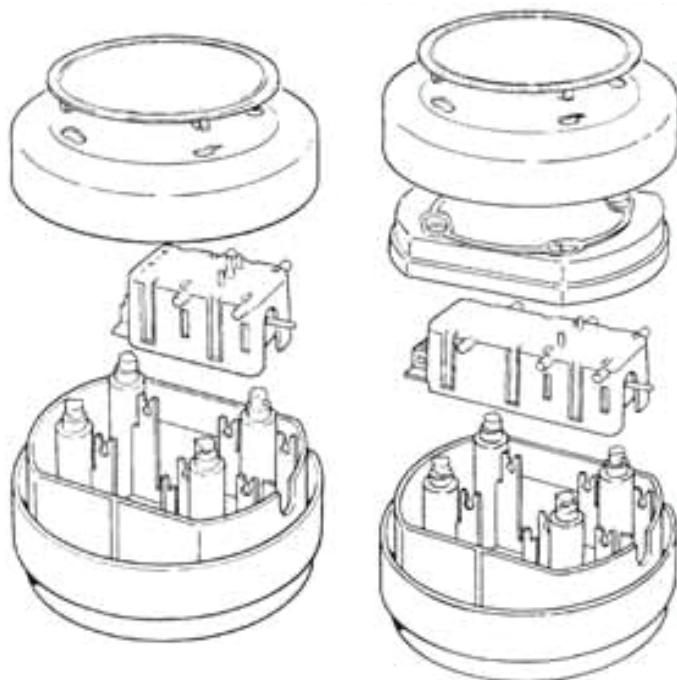

- I. Bells certified under the CPR for Fire Alarm Applications, are shown in the column marked EN54-3.
- II. EN54-3 measurements shown reflect minimum expected SPL reading at the Loudest Point around the EN54-3 defined sounder axis.
- III. All other tone measurements reflect manufactures data, and are not verified by a Notified Body.
- IV. Detailed EN54-3 polar SPL measurements are available in the Product Manual M05-006.
- V. All other measurements are taken at 20°C operating temperature.
- VI. Enclosure protection, IP21C, Type A
Weatherproof version, IP33C, Type B

Important note:

The mains version should only be installed by a suitably qualified person.

The mains supply should be isolated before removing the cover. Ensure that the gong fixing screw is refitted after installation. The supply must be wired using cable of no greater than 6A rating and a cross sectional area of 0.75mm². The cable must be secured using a suitable cable gland.

A readily accessible disconnect device must be incorporated in the mains supply wiring to this unit. Refer to current wiring regulations.

The unit should be powered via a 1A 250V anti-surge fuse (T1A250V).



F/WP Kit**



** Weatherproofing kit must be used for outdoor (type B) installations

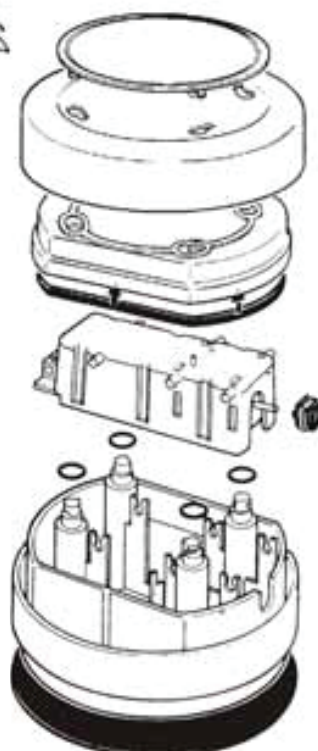

Important note:

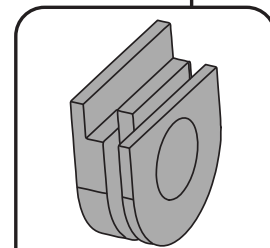
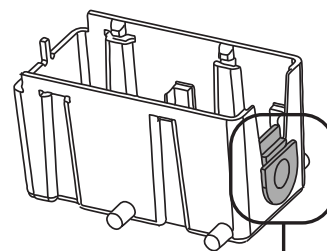

When fitting plunger seal into motor box, ensure larger hole on seal is facing outwards

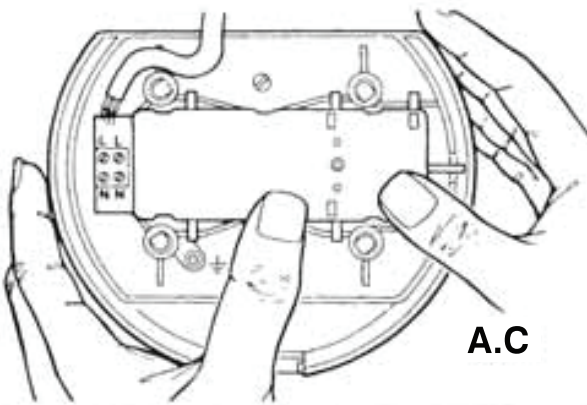
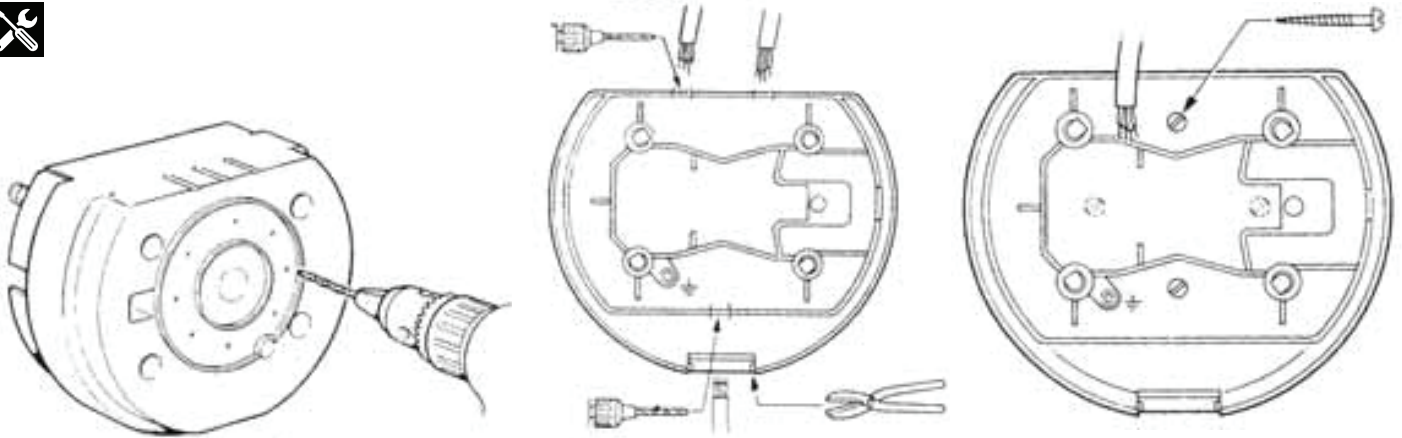

A.C

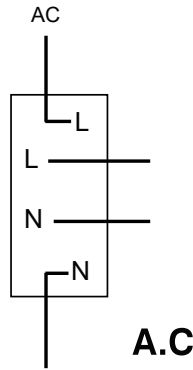

A.C

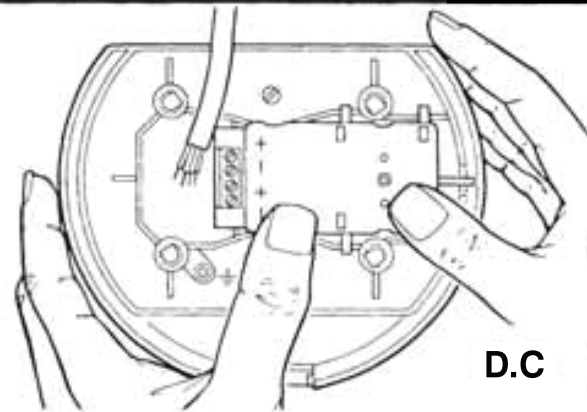

D.C

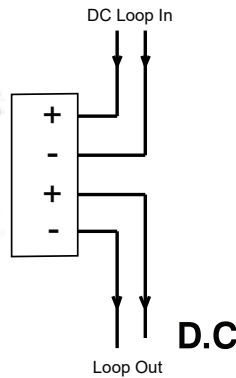

D.C

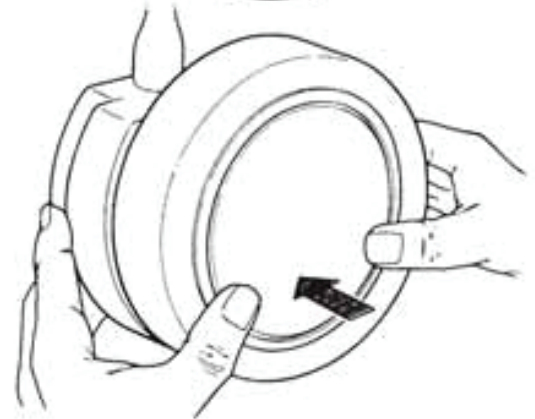

Powering Business Worldwide

Eaton Electrical Products Ltd.
Llantarnam Park
Cwmbran
NP44 3AW
Tel: +44 (0) 1633 628500
Fax: +44 (0) 1633 866346

Eaton
EMEA Headquarters
Route de la Longeraie 7
1110 Morges, Switzerland
Eaton.eu
TEL: +44 (0) 1302 321541
FAX: +44 (0) 1302 303220
Firesales@eaton.com
Firetechsupport@eaton.com

© 2020 Eaton
All Rights Reserved
Eaton is a registered trademark.

All trademarks are property
of their respective owners.
www.Eaton.com