

WP3-BG Weatherproof Break Glass Manual Call Point

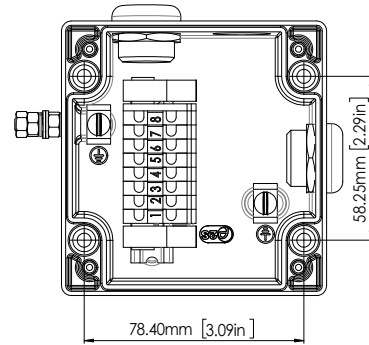

View of base unit showing fixing centres

To gain access to the mounting holes in the base the front cover must be removed. This is achieved by removing the 4 off M4 cap head bolts holding on the cover.

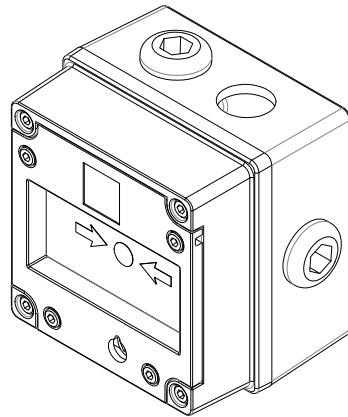
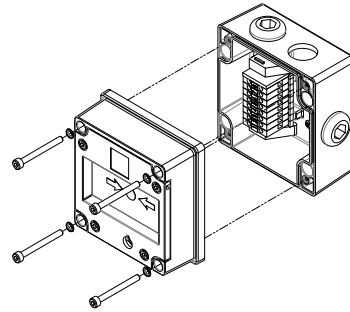

Once the screws are removed the cover will hang down out of the way to gain access to the terminals, the internal earth terminal and mounting hole recesses.

3) Earthing

The unit has both internal and external earth terminals. It is recommended that a cable crimp lug is used on the earth wires. The internal earth wire is placed under a earth clamp which will stop the cable twisting. This is secured by an M4 screw and spring washer. The external earth lug should be located between the two M5 washers provided and securely locked down with the M5 spring washer and two locknuts.

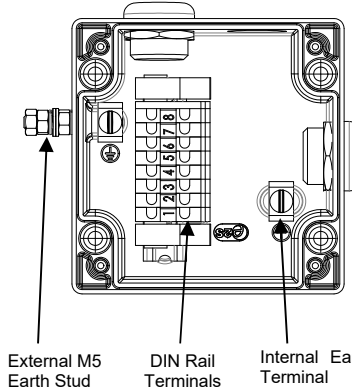

4) Cable connections

There are 3 off cable entries for M20x1.5 cable glands or stopping plugs

Wired connections are to be made to the terminals on the DIN Rail (0.5mm² - 4.0mm² wire size). See Section 8 for wiring schematics.

5) Testing unit operation

The break glass unit can be tested without the need to break/replace the frangible glass element. A test key is used to mechanically drop the glass down activating the switch.

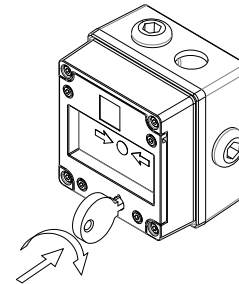

The test key is inserted in the test cam and rotated clockwise by an angle of 60°. The glass element will visibly drop down in the viewable window.

The call point switch will now change over its contacts to operate the alarm.

Once testing is complete the unit needs to be reset, the test key is rotated back anticlockwise by an angle of 60° back to its original position. The glass element should now raise up so it is level again in the viewable window.

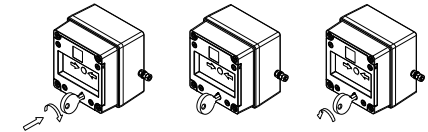

1. Insert test Key rotate clockwise 60°
2. Hold in position during test
3. Rotate back anticlockwise to reset

6) Replacement of glass element

If the break glass unit has been operated the broken glass element can be quickly replaced.

The break glass cover plate is removed by unscrewing the 4 off M4 cap head screws attaching it.

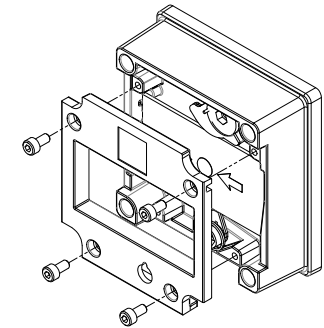

Once the cover is removed the broken glass will be free to be removed, clean out any other fragments of glass carefully.

1) Introduction

The WP3-BG is a break glass manual call point designed to withstand harsh environments. It has the following ratings:

CE Marking:



IP Rating:
IP66/67

Ambient Temperature Range:
-40°C to +75°C

Input Voltage:
AC voltage 250V Max. Current 5.0A Max.
DC voltage 48V Max. Current 1.0A Max.
DC voltage 24V Max. Current 3.0A Max.

The enclosure is manufactured from Aluminium LM6 with an epoxy powder coat paint finish.

2) Call Point Location and Mounting

The location of the call point should enable ease of access for operation and testing. The unit should be mounted using the 4 off fixing holes which will accept up to M4 sized fixings.

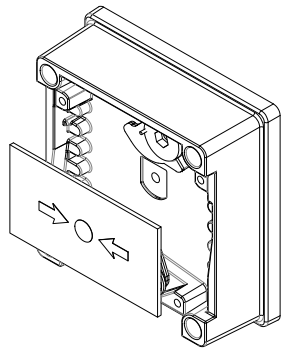

To fit the new glass element rotate the top cam clockwise by an angle of 50° (use a 6mm Allen key) this will then allow the glass to fit back into the pocket it sits in, resting on the pivot point and test cam, release the top cam to rest on the top of the glass element.

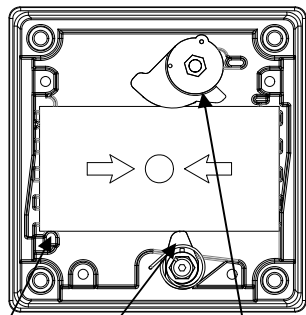

Pivot point Test Cam Top Cam (rotate)

Replace the cover plate and tighten the 4 off M4 cap head screws.

Ensure the glass element is free to move under the cover plate. This can be done by running through the units test operation. See section 5 of this instruction manual.

7) End-of-Line and Series Devices

All models can be fitted with series resistors, end-of-line monitoring resistors, monitoring diodes, Zener diodes and also specific customer modules if supplied with direct current up to 50Vdc.

Part codes:

EOL (End of Line) device:

- Resistor – ExxxR
- Diode – ED1
- Zener – ExxxZ

Series (In line) device:

- Resistor – SxxxR
- Diode – SD1
- Zener – SxxxZ

The unit can be wired with a maximum of 2 module devices – see wiring diagrams

When customer is fitting EOL or Series device ensure device leads are insulated or routed so as not to create an electrical short circuit.

The following table 1 shows limitations for all devices.

Type of component fitted	Suggested EOL/ Series Device Type Value
End-of-Line Resistor	330Ω Suggested Min.
End-of-Line Diode Type 1N5401	2W
Series Resistor	330Ω Suggested Min.
Series Zener Diode Type 1N5333B	3.3V 4.7V 5.1V 5.6V 6.2V 6.8V 10V 12V
Suggested Sizes	

8) Wiring Diagrams WP3-BG-S

8.1) Standard Unit Without series / EOL devices

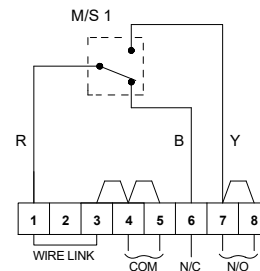

1A - Circuit shown in Unoperated condition (Glass Intact / Standby Condition)
Terminals (4,5) & (7,8) open
Terminals (4,5) & (6) closed

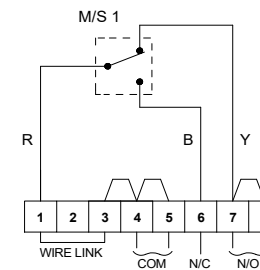

1B - Circuit shown in Operated condition (Glass Broken)
Terminals (4,5) & (7,8) closed
Terminals (4,5) & (6) open

8.2) Standard Unit With optional series / EOL devices

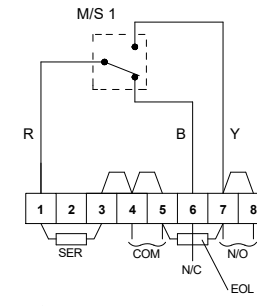

2A - Circuit shown in Unoperated condition (Glass Intact / Standby Condition)
Terminals (4,5) & (7,8) open
Terminals (4,5) & (6) closed

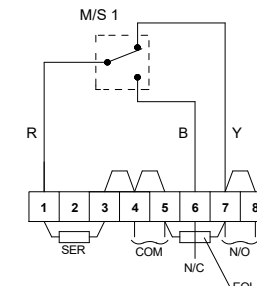

2B - Circuit shown in Operated condition (Glass Broken)
Terminals (4,5) & (7,8) closed
Terminals (4,5) & (6) open

When fitting diodes or Zener diodes, polarity across Series & EOL devices must be observed as follows:

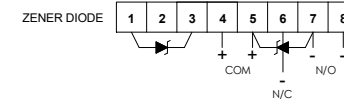
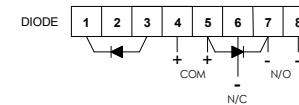

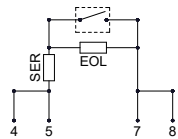

8.3) Standard Unit with Alternative Configuration of series / EOL devices

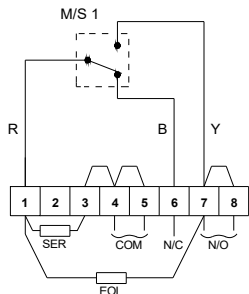

3A - Circuit shown in Unoperated condition
(Glass Intact / Standby Condition)
Terminals (4,5) & (7,8) open
Terminals (4,5) & (6) closed

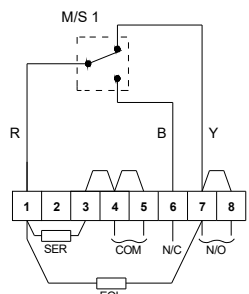

3B - Circuit shown in Operated condition
(Glass Broken)
Terminals (4,5) & (7,8) closed
Terminals (4,5) & (6) open

When fitting diodes or Zener diodes, polarity across Series & EOL devices must be observed as follows:

