



The CXM has simple changeover contacts for use with a wide range of fire systems. The unit is supplied with both a glass and re-settable plastic element. The CXM is aimed at legacy systems.

### Features

- Choice of glass or plastic elements
- Changeover contacts
- Potted waterproof option
- Flag on re-settable element

### Benefits

- Select element depending on location and user preference
- Wide range of usages
- Suitable for outdoor use
- Quick, visible alarm identification

### Dimensions

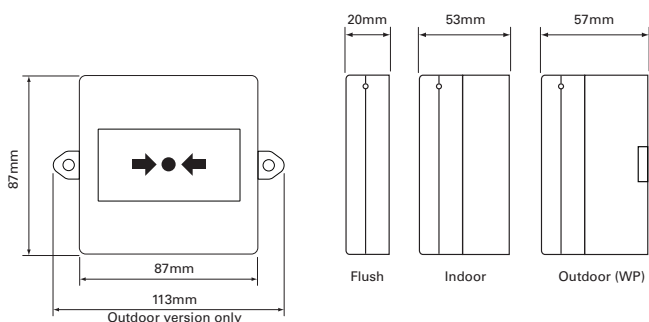

### Technical Specification

<b>Voltage</b>	9 - 30Vdc
<b>Current Rating</b>	3A
<b>Switching</b>	SPCO
<b>Element Type</b>	Glass / Plastic (resettable)
<b>Temperature</b>	- 10°C to + 55°C - 25°C to + 70°C (WP)
<b>Protection</b>	IP24D, IP66 (WP)
<b>Construction</b>	ABS
<b>Weight</b>	0.19Kg, 0.22Kg (WP)
<b>Colours</b>	Red*

\* Other colours available - minimum order required.

Call point range also available in different colours for non-fire applications



### Catalogue Numbers

Reference	Cat No	Description
CXM/CO/GP/R/BB	4930010FUL-0048XC	Indoor call point, Red Body with back box, Glass element provided
CXM/CO/G/R/WP	4990073FULL-0122X	Weatherproof call point for outdoor use with IP66 backbox, Red body, Glass element provided.

For full list of part numbers, turn to page 83

