

NFS2-8

2, 4 & 8 Zone Non-Addressable Fire Alarm Panel

Section: Non-addressable Fire Alarm Panels

FEATURES

- **Conforms to EN54 & ISO7240**
- **Simple to install**
- **2, 4 or 8 zone versions**
- **Robust fire resistant ABS moulded enclosure**
- **Battery space for up to 72 hour stand-by**
- **Day / night mode investigation delay timers**
- **2 outputs configurable as:**
 - ✓ Sounder Circuits
 - ✓ Fire Routing Circuits
 - ✓ Fault Routing Outputs
- **2 inputs configurable as :**
 - ✓ Day / night switching
 - ✓ Class change
 - ✓ Alert
 - ✓ Evacuate
 - ✓ Reset
 - ✓ Fire transmission confirmed
 - ✓ Fault transmission confirmed
- **Zones configurable as :**
 - ✓ Latching / Non-latching
 - ✓ Resistive / Short circuit alarm
 - ✓ Zonal day / night inclusion
 - ✓ Coincidence (paired with other zones)
 - ✓ Sprinkler Delay

- **8 Way relay card configurable as:**

- ✓ 8 Zonal outputs.
- ✓ 4 Pairs of coincident outputs.
- ✓ 4 Inputs and 4 outputs.
- ✓ Relay function configurable as normally open or normally closed.

GENERAL

The NFS2-8 zone conventional fire alarm panels have been developed for both installers and end users with efficiency in mind, offering a technically advanced range of facilities and functions while remaining easy to install, program and operate. A full range of non-addressable detectors, advanced non-addressable detectors, beam detectors, manual call points, duct-mounting applications, audible and visible devices complement the NFS 2-8 series.

The NFS2-8 2, 4 or 8 zone non-addressable fire alarm panels are ideally suited for facilities such as offices, shop units, public houses, B & B, clubs, small industrial units, nursing homes, schools, etc. offering a wide range of benefits to installer and end-users.

The NFS2-8 non-addressable panels have been designed to comply with both European EN54 and International ISO 7240 Codes of Practice- Parts 2 & 4.

INSTALLATION

The NFS2-8 fire alarm panels are designed to simplify installation. The enclosure consists of a two part arrangement of front cover and back



box. The back box contains a top and centred key hole fixing with two additional fixing points that are angled to provide final alignment.

Eighteen knockouts in the top of the back box provide ample cable entry points and is suitable for both standard and enhanced cables.

All cable connections are conveniently located along the top edge of the control and P.S.U. modules. Screw terminals are provided and allow for cable cores up to and including 2.5mm C.S.A.

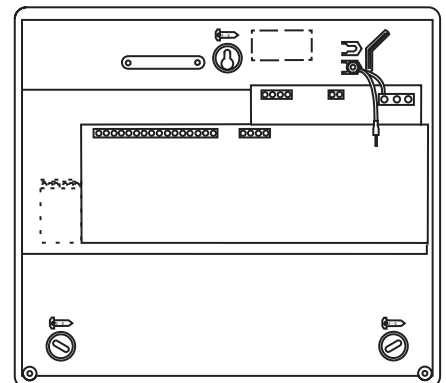
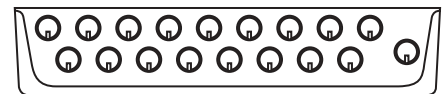

This document is not intended to be used for installation purposes. Every care has been taken in the preparation of this document but no liability can be accepted for the use of the information therein. Design features may be changed or amended without prior notice. For more information, contact **NOTIFIER** Charles Avenue, Burgess Hill, West Sussex, RH15 9UF. United Kingdom Phone: +44 (0) 1444 230 300 Fax: +44 (0) 1444 230 888 E-mail: sales@notifierfiresystems.co.uk

ISO9001
 Design, Manufacture and Supply
 to Quality Management Systems
 Certified to ISO9001:1994



SPECIFICATIONS

• Dimensions

- ✓ Height: 318mm
- ✓ Width: 356mm
- ✓ Depth: 96mm
- ✓ Weight: 2kg (no batteries)

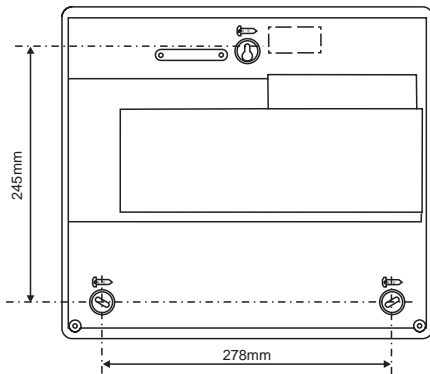

• Electrical

- ✓ Supply rating: 230V~(ac) ± 15%, 50 / 60Hz, 1.6A
- ✓ Output voltage: 18.5 - 28.5Vdc
- ✓ Output current: 1.8A (includes charger current - charger disabled during alarm)

• Environmental Limits

- ✓ Operating temperature: -5°C to +45°C
- ✓ 5% to 95%, non-condensing relative humidity
- ✓ IP rating: IP30

• Push Button Controls

- ✓ ACCEPT
- ✓ SOUNDER STOP/START
- ✓ RESET
- ✓ BUZZER MUTE
- ✓ DELAY ON/OFF
- ✓ ITEM SELECT
- ✓ DISABLE/TEST/NORMAL
- ✓ LAMP TEST

• LED Indicators

- ✓ Red "Common Fire"
- ✓ Red zonal "Fire" (one per zone)
- ✓ Yellow zonal "Fault/Disable/Test" (one per zone)
- ✓ Yellow "Fault"
- ✓ Yellow "Disablement"
- ✓ Yellow "Test"
- ✓ Yellow "Delay On"
- ✓ Yellow "System Fault"
- ✓ Yellow "Earth Fault"
- ✓ Yellow "Power supply Fault"
- ✓ Yellow "Sounder Fault/Disabled"
- ✓ Yellow "Fire O/P Active"
- ✓ Yellow "Fire O/P Fault/Disabled"
- ✓ Yellow "Fault O/P Fault/Disabled"
- ✓ Yellow "Auxiliary Fault"
- ✓ Green "Power"

ORDERING INFORMATION

Part No.	Description
002-490-129	Two zone non-addressable fire alarm panel, complete with fire/fault reley and capacitor end of line.
002-490-149	Four zone non-addressable fire alarm panel, complete with fire/fault reley and capacitor end of line.
002-490-189	Eight zone non-addressable fire alarm panel, complete with fire/fault reley and capacitor end of line.

Accessories:

020-747	8 Way relay card. Adds 8 configurable relays. These can be configured as inputs or outputs.
020-745-008	Spare installation kit. Includes 8 capacitive end of lines, battery leads, Allen key, panel controls key and sounder end of line resistors.
020-710-002	Spare text inserts.
020-743	Capacitor kit for detectors not compatible with capacitive EOL monitoring. Includes 8 x 10µf capacitors. Active EOL's required - See part number 020-417.
020-417	Active end of line monitor module.

Wiring Diagram

