

SIEMENS

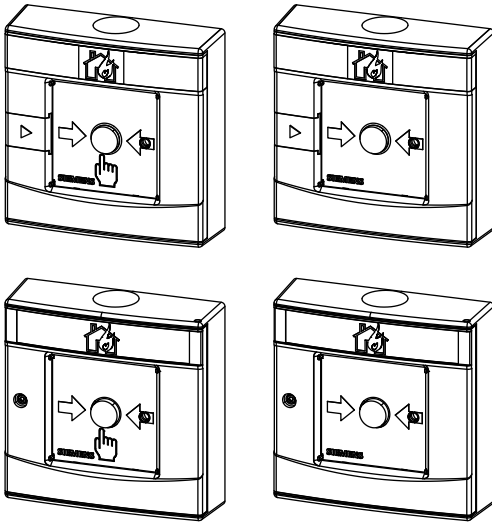

FDM223, FDM224, FDM223H, FDM224H

Manual call point

Technical Manual

Imprint

Technical specifications and availability subject to change without notice.

Transmittal, reproduction, dissemination and/or editing of this document as well as utilization of its contents and communication thereof to others without express authorization are prohibited. Offenders will be held liable for payment of damages. All rights created by patent grant or registration of a utility model or design patent are reserved.

Issued by:
Siemens Switzerland Ltd.
Smart Infrastructure
Global Headquarters
Theilerstrasse 1a
CH-6300 Zug
Tel. +41 58 724-2424
www.siemens.com/buildingtechnologies

Edition: 2019-10-16
Document ID: 007002_k_en_--

© Siemens Switzerland Ltd, 2004

Table of contents

1	About this document	5
1.1	Applicable documents	7
1.2	Download center.....	7
1.3	Technical terms	7
1.4	History of changes.....	8
2	Safety	9
2.1	Safety instructions	9
2.2	Safety regulations for the method of operation.....	10
2.3	Standards and directives complied with	12
2.4	Release Notes	12
3	Structure and function	13
3.1	Overview.....	13
3.1.1	Details for ordering	14
3.1.2	Product version ES	15
3.2	Setup	16
3.2.1	Manual call points FDM223H and FDM224H	16
3.2.2	Manual call points FDM223H and FDM224H	17
3.2.3	Connections.....	18
3.2.4	Indication elements.....	18
3.3	Function.....	19
3.3.1	Danger levels.....	19
3.3.2	Internal alarm indicator	19
3.3.3	Line separator.....	19
3.3.4	Test mode.....	19
3.3.5	Interface to service devices	20
3.3.6	Diagnosis levels.....	20
3.3.7	Behavior in degraded mode.....	21
3.3.8	Line tester	21
3.4	Accessories	22
3.4.1	Housing for manual call point FDMH293-x	22
3.4.2	Housing for manual call point FDMH297-R	22
3.4.3	Housing for manual call point FDMH292-R	22
3.4.4	Key DMZ1195.....	23
3.4.5	Glass insert DMZ1196-AC.....	23
3.4.6	Protective cover DMZ1197-AC	23
3.4.7	Seal DMZ1197-AD.....	24
3.4.8	Seal FDMP223	24
3.4.9	Auxiliary terminal	24
3.4.10	Cable gripper (2-hole).....	24
3.4.11	M20 x 1.5 metal cable gland.....	25
4	Planning	26
4.1	Compatibility FDnet/C-NET	26
4.2	Fields of application.....	26
4.3	Mounting site	26
4.4	Environmental influences	26
5	Mounting / Installation	27
5.1	Preparation	27

5.2	Installation	29
5.3	Installation	31
5.3.1	Mounting the seal FDMP223	34
5.4	Installing the protective cover	35
5.5	Installing the stickers	36
5.6	Attaching the window sign	37
6	Commissioning	38
6.1	Localization and device testing.....	38
6.2	Checking function	39
7	Maintenance / Repair	43
7.1	Resetting after an alarm	43
7.2	Status query	44
7.3	Performance check.....	44
7.4	Replacing the glass insert	45
8	Specifications	47
8.1	Technical data	47
8.2	Dimensions	49
8.3	Master gauges for holes	50
8.4	Environmental compatibility and disposal.....	51
	Index.....	52

1 About this document

Goal and purpose

This document contains all information on the manual call points

- FDM223
- FDM224
- FDM223H
- FDM224H

Following the instructions consistently will ensure that the product can be used safely and without any problems.

Intended use

The manual call points FDM223, FDM224, FDM223H, and FDM224H can only be used for the manual activation of fire alarms in a fire detection system FS20 or FS720.

Target groups

The information in this document is intended for the following target groups:

Target group	Activity	Qualification
Product Manager	<ul style="list-style-type: none"> • Is responsible for information passing between the manufacturer and regional company. • Coordinates the flow of information between the individual groups of people involved in a project. 	<ul style="list-style-type: none"> • Has obtained suitable specialist training for the function and for the products. • Has attended the training courses for Product Managers.
Project Manager	<ul style="list-style-type: none"> • Coordinates the deployment of all persons and resources involved in the project according to schedule. • Provides the information required to run the project. 	<ul style="list-style-type: none"> • Has obtained suitable specialist training for the function and for the products. • Has attended the training courses for Project Managers.
Project engineer	<ul style="list-style-type: none"> • Sets parameters for product depending on specific national and/or customer requirements. • Checks operability and approves the product for commissioning at the place of installation. • Is responsible for troubleshooting. 	<ul style="list-style-type: none"> • Has obtained suitable specialist training for the function and for the products. • Has attended the training courses for Product Engineer.
Installation personnel	<ul style="list-style-type: none"> • Assembles and installs the product components at the place of installation. • Carries out a function check following installation. 	<ul style="list-style-type: none"> • Has received specialist training in the area of building installation technology or electrical installations.
Maintenance personnel	<ul style="list-style-type: none"> • Carries out all maintenance work. • Checks that the products are in perfect working order. • Searches for and corrects malfunctions. 	<ul style="list-style-type: none"> • Has obtained suitable specialist training for the function and for the products.

Document identification

The document ID is structured as follows:

ID code	Examples
ID_ModificationIndex_Language_COUNTRY -- = multilingual or international	A6V10215123_a_de_DE A6V10215123_a_en_-- A6V10315123_a_--_--

Date format

The date format in the document corresponds to the recommendation of international standard ISO 8601 (format YYYY-MM-DD).

Conventions for text marking

Markups

Special markups are shown in this document as follows:

▷	Requirement for a behavior instruction
1. 2.	Behavior instruction with at least two operation sequences
–	Version, option, or detailed information for a behavior instruction
⇒	Intermediate result of a behavior instruction
⇒	End result of a behavior instruction
•	Numbered lists and behavior instructions with an operation sequence
[→ X]	Reference to a page number
'Text'	Quotation, reproduced identically
<Key>	Identification of keys
>	Relation sign and for identification between steps in a sequence, e.g., 'Menu bar' > 'Help' > 'Help topics'
↑ Text	Identification of a glossary entry

Supplementary information and tips



The 'i' symbol identifies supplementary information and tips for an easier way of working.

1.1 Applicable documents

Document ID	Title
007001	Data sheet Manual call points FDM221, FDM223, FDM224
007227	Technical manual Detector exchanger and tester FDUD292
007905	Installation Housing for manual call point FDMH293-x, FDMH297-R, Switching unit FDME223, FDME224
008250	Technical Manual Line tester FDUL221
008331	List of compatibility (for 'Sinteso™' product line)
008345	Data sheet Manual call points 'Heavy Duty' FDM223H, FDM224H
008615	Installation Housing for manual call point 'Heavy Duty' FDMH292-R
009052	FS20 Fire detection system - Commissioning, Maintenance, Troubleshooting
009718	Technical Manual Intelligent detector tester FDUD293
A6V10210416	FS720 Fire detection system - Commissioning, Maintenance, Troubleshooting
A6V10229261	List of compatibility (for 'Cerberus™ PRO' product line)

1.2 Download center

You can download various types of documents, such as data sheets, installation instructions, and license texts via the following Internet address:

<https://siemens.com/bt/download>

- Enter the document ID in the search field.



You will also find information about search variants and links to mobile applications (apps) for various systems on the home page.

1.3 Technical terms

Term	Explanation
FDnet/C-NET	Addressed detector line
LED	Light-emitting diode
MC link	Maintenance and commissioning link (proximity interface)

1.4 History of changes

The reference document's version applies to all languages into which the reference document is translated.



The first edition of a language version or a country variant may, for example, be version 'd' instead of 'a' if the reference document is already this version.

The table below shows this document's revision history:

Version	Edition date	Brief description
k	2019-10-16	<ul style="list-style-type: none"> Information about seal FDMP223 added in the 'Accessories', 'Installation', and 'Technical data' chapters 'Accessory' chapter: Cable gripper (1-hole) replaced by cable gripper (2-hole)
j	2018-02-01	<ul style="list-style-type: none"> Changes in the 'Technical data' chapter
i	2016-02-23	<ul style="list-style-type: none"> Changes in the 'Technical data' chapter
h	2015-09-02	<ul style="list-style-type: none"> New door used for all manual call points 'Replacing the glass insert' chapter revised 2-hole cable grippers removed from accessories available to purchase Intended use added Editorial changes
g	2014-05-05	<p>V-pins removed from text and accessories Mounting height changed from 1.3...1.6 m to 0.9...1.6 m Data sheet updated in 'Applicable documents' chapter FDM221 removed from the document and included in document 009757. Housing FDMH297-R added. Accessories and spare parts added and restructured. Document edited. Change to date format in line with ISO 8601 specifications (yyyy-mm-dd format).</p>
f	11.2007	<p>FDM223H and FDM224H in text and added with graphics FDMH292/3-x IP64 -> IP65</p>
e	09.2007	<p>Standards added Diagnosis levels adapted</p>
d	07.2007	<p>Technical terms added. Supplements in the Technical data: - Line separator - IP protection categories - Standard EN 54-17 - VdS and LPCB approvals added</p>
c	09.2006	<p>FDM224 included Diagnosis levels added</p>
b	01.2005	Name of division
a	01.2004	First edition

2 Safety

2.1 Safety instructions

The safety notices must be observed in order to protect people and property. The safety notices in this document contain the following elements:







- Symbol for danger
- Signal word
- Nature and origin of the danger
- Consequences if the danger occurs
- Measures or prohibitions for danger avoidance

Symbol for danger

	This is the symbol for danger. It warns of risks of injury . Follow all measures identified by this symbol to avoid injury or death.
---	--

Additional danger symbols

These symbols indicate general dangers, the type of danger or possible consequences, measures and prohibitions, examples of which are shown in the following table:

	General danger		Explosive atmosphere
	Voltage/electric shock		Laser light
	Battery		Heat

Signal word

The signal word classifies the danger as defined in the following table:

Signal word	Danger level
DANGER	'DANGER' identifies a dangerous situation, which will result directly in death or serious injury if you do not avoid this situation.
WARNING	'WARNING' identifies a dangerous situation, which may result in death or serious injury if you do not avoid this situation.
CAUTION	'CAUTION' identifies a dangerous situation, which could result in slight to moderately serious injury if you do not avoid this situation.
<i>NOTICE</i>	'NOTICE' identifies a possibly harmful situation or possible damage to property that may result from non-observance. 'NOTICE' does not relate to possible bodily injury.

How risk of injury is presented

Information about the risk of injury is shown as follows:

	⚠ WARNING
	Nature and origin of the danger Consequences if the danger occurs <ul style="list-style-type: none"> • Measures / prohibitions for danger avoidance

How possible damage to property is presented

Information about possible damage to property is shown as follows:

	NOTICE
	Nature and origin of the danger Consequences if the danger occurs <ul style="list-style-type: none"> • Measures / prohibitions for danger avoidance

2.2 Safety regulations for the method of operation



National standards, regulations and legislation

Siemens products are developed and produced in compliance with the relevant European and international safety standards. Should additional national or local safety standards or legislation concerning the planning, mounting, installation, operation or disposal of the product apply at the place of operation, then these must also be taken into account together with the safety regulations in the product documentation.

Electrical installations

	⚠ WARNING
	Electrical voltage Electric shock <ul style="list-style-type: none"> • Work on electrical installations may only be carried out by qualified electricians or by instructed persons working under the guidance and supervision of a qualified electrician, in accordance with the electrotechnical regulations.

- Wherever possible disconnect products from the power supply when carrying out commissioning, maintenance or repair work on them.
- Lock volt-free areas to prevent them being switched back on again by mistake.
- Label the connection terminals with external voltage using a 'DANGER External voltage' sign.
- Route mains connections to products separately and fuse them with their own, clearly marked fuse.
- Fit an easily accessible disconnecting device in accordance with IEC 60950-1 outside the installation.
- Produce earthing as stated in local safety regulations.

	⚠ CAUTION
	Noncompliance with the following safety regulations Risk of injury to persons and damage to property <ul style="list-style-type: none"> • Compliance with the following regulations is required.
	<ul style="list-style-type: none"> • Specialist electrical engineering knowledge is required for installation. • Only an expert is permitted to carry out installation work. Incorrect installation can take safety devices out of operation unbeknown to a layperson.

Mounting, installation, commissioning and maintenance

- If you require tools such as a ladder, these must be safe and must be intended for the work in hand.
- When starting the fire control panel ensure that unstable conditions cannot arise.
- Ensure that all points listed in the 'Testing the product operability' section below are observed.
- You may only set controls to normal function when the product operability has been completely tested and the system has been handed over to the customer.

Testing the product operability

- Prevent the remote transmission from triggering erroneously.
- If testing building installations or activating devices from third-party companies, you must collaborate with the people appointed.
- The activation of fire control installations for test purposes must not cause injury to anyone or damage to the building installations. The following instructions must be observed:
 - Use the correct potential for activation; this is generally the potential of the building installation.
 - Only check controls up to the interface (relay with blocking option).
 - Make sure that only the controls to be tested are activated.
- Inform people before testing the alarm devices and allow for possible panic responses.
- Inform people about any noise or mist which may be produced.
- Before testing the remote transmission, inform the corresponding alarm and fault signal receiving stations.

Modifications to the system design and the products

Modifications to the system and to individual products may lead to faults, malfunctioning and safety risks. Written confirmation must be obtained from Siemens and the corresponding safety bodies for modifications or additions.

Modules and spare parts

- Components and spare parts must comply with the technical specifications defined by Siemens. Only use products specified or recommended by Siemens.
- Only use fuses with the specified fuse characteristics.
- Wrong battery types and improper battery changing lead to a risk of explosion. Only use the same battery type or an equivalent battery type recommended by Siemens.
- Batteries must be disposed of in an environmentally friendly manner. Observe national guidelines and regulations.

Disregard of the safety regulations

Before they are delivered, Siemens products are tested to ensure they function correctly when used properly. Siemens disclaims all liability for damage or injuries caused by the incorrect application of the instructions or the disregard of danger warnings contained in the documentation. This applies in particular to the following damage:

- Personal injuries or damage to property caused by improper use and incorrect application
- Personal injuries or damage to property caused by disregarding safety instructions in the documentation or on the product
- Personal injury or damage to property caused by poor maintenance or lack of maintenance

2.3 Standards and directives complied with

A list of the standards and directives complied with is available from your Siemens contact.

2.4 Release Notes

Limitations to the configuration or use of devices in a fire detection installation with a particular firmware version are possible.

	⚠ WARNING
	<p>Limited or non-existent fire detection</p> <p>Personal injury and damage to property in the event of a fire.</p> <ul style="list-style-type: none"> • Read the 'Release Notes' before you plan and/or configure a fire detection installation. • Read the 'Release Notes' before you carry out a firmware update to a fire detection installation.

	NOTICE
	<p>Incorrect planning and/or configuration</p> <p>Important standards and specifications are not satisfied. Fire detection installation is not accepted for commissioning. Additional expense resulting from necessary new planning and/or configuration.</p> <ul style="list-style-type: none"> • Read the 'Release Notes' before you plan and/or configure a fire detection installation. • Read the 'Release Notes' before you carry out a firmware update to a fire detection installation.

3 Structure and function

3.1 Overview

The manual call points are intended for use in places where a fire can be detected by people who can manually trigger an alarm.

The manual call points consist of a housing and a switching unit. They have the following features:

- Manual call points FDM223 and FDM223H with indirect activation [→ 16]
- Manual call points FDM224 and FDM224H with direct activation [→ 17]
- Two-wire installation for all cable types
- Individual detector addressing
- Indication of the condition (Alarm, localization or test) by means of a dichromatic LED
- Integrated line separation function
- Communication via FDnet/C-NET
- Manual call points FDM223H and FDM224H:
 - Very robust housing design made from fiberglass-reinforced thermoplast
 - For surface mounting in humid, wet and dusty environments
- Housing FDMH297-R:
 - Housing optimized for the migration of old manual call points in wall hydrants, for example. Height and width of housing same as old SIGMASYS manual call points.
 - Not suitable for use in wet areas.

Manual call points in housing FDMH293-x or FDMH297-R

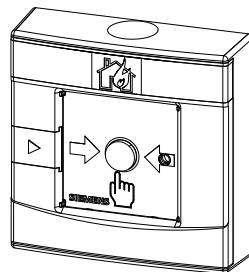

Manual call point FDM223

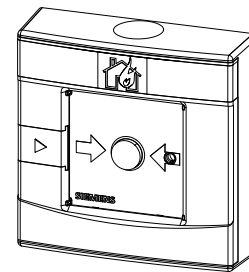

Manual call point FDM224

Manual call point in housing FDMH292-R

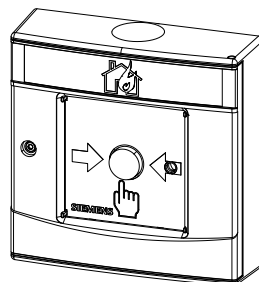

Manual call point FDM223H

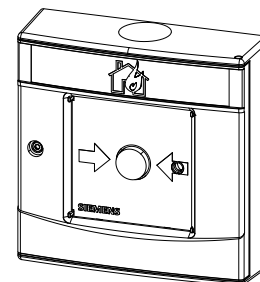

Manual call point FDM224H

See also

- Manual call points FDM223H and FDM224H [→ 16]
- Manual call points FDM223H and FDM224H [→ 17]

3.1.1 Details for ordering

Design and component combinations:

Manual call point				Type	Order no.	Designation Scope of delivery
FDM223	FDM224	FDM223H	FDM224H			
Complete device						
x	-	-	-	FDM223 (complete)	A5Q00008098	Red housing (FDMH293-R) with glass insert, key, switching unit (FDME223), 2 cable grippers (2-hole), and 'Fire brigade' and 'Fire detector' window signs
Switching units						
x	-	x	-	FDME223	A5Q00003087	Switching unit for indirect activation
-	x	-	x	FDME224	A5Q00009392	Switching unit for direct activation
Housing						
x	x	-	-	FDMH293-R	A5Q00004023	Red housing with glass insert and key (134 x 134 mm)
x	x	-	-	FDMH293-Y	A5Q00004908	Yellow housing with glass insert and key (134 x 134 mm)
x	x	-	-	FDMH293-B	A5Q00004909	Blue housing with glass insert and key (134 x 134 mm)
x	x	-	-	FDMH293-G	A5Q00004911	Green housing with glass insert and key (134 x 134 mm)
x	x	-	-	FDMH293-O	S54311-F2-A1	Orange housing with glass insert and key (134 x 134 mm)
x	x	-	-	FDMH297-R	S54311-B7-A1	Red housing with glass insert and key (130 x 130 mm)
-	-	x	x	FDMH295-R	S54311-B7-A1	Red 'Heavy Duty' housing with glass insert, Allen key, 3 cable grippers (2-hole) and 'Fire brigade' and 'Fire detector' self-adhesive stickers

3.1.2 Product version ES

The product version ES provides the technical status of a device in terms of software and hardware. The product version is provided as a two-digit number.

You will find the details of your device's product version:

- On the packaging label
- On the product label or the type plate

Product version on the packaging label

Details of the product version can be found directly on the packaging label in the barcode:

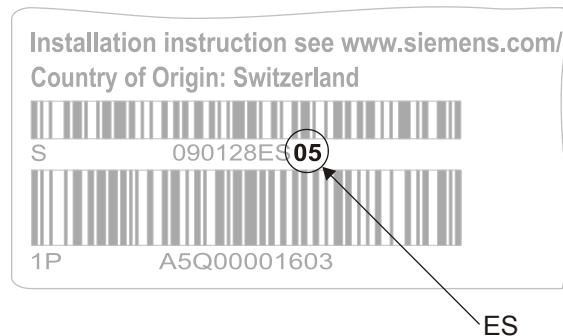

Figure 1: Example of a packaging label with details of the product version

Product version on the product label and the type plate

Details of the product version can be found after the device order number:

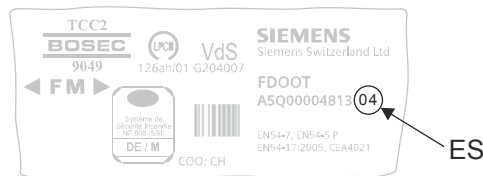

Figure 2: Example of a product label with details of the product version



Depending on the product and various approvals, the product labels may differ in terms of the information type and layout.

Look for your device's order number on the product label.

You will find the product version after the order number.

3.2 Setup

3.2.1 Manual call points FDM223H and FDM224H

The manual call point FDM223 triggers an alarm when the glass insert is pushed in and the alarm button is pressed (indirect activation). The alarm is immediately transmitted to the control panel.

The manual call point FDM224 triggers an alarm when the glass insert is pushed in. The alarm button, which is pre-stressed by the glass insert, then pops out (direct activation). The alarm is immediately transmitted to the control panel.



To reset the manual call points after an alarm, the switching unit must be reset with the locking lever and a new glass insert must be inserted.

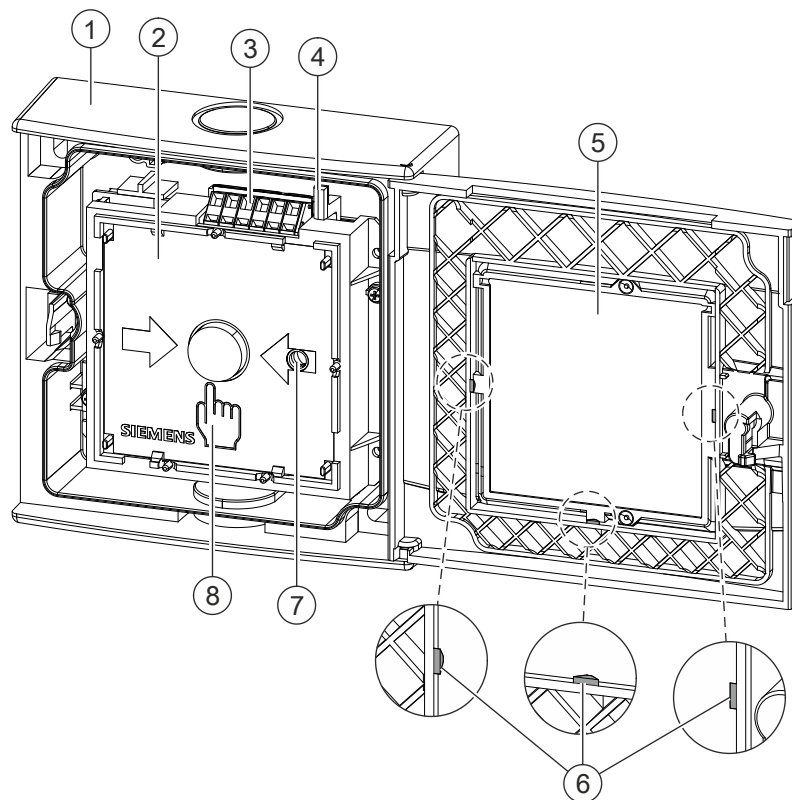

Figure 3: Manual call point FDM223 with housing FDMH293-x or FDMH297-R with open door

- | | | | |
|---|----------------|---|-----------------------------|
| 1 | Housing | 5 | Glass insert |
| 2 | Switching unit | 6 | Guides for the glass insert |
| 3 | Spring clips | 7 | Internal alarm indicator |
| 4 | Locking lever | 8 | Alarm button |

3.2.2 Manual call points FDM223H and FDM224H

The manual call point FDM223H triggers an alarm when the glass insert is pushed in and the alarm button is pressed (indirect activation). The alarm is immediately transmitted to the control panel.

The manual call point FDM224H triggers an alarm when the glass insert is pushed in. The alarm button, which is pre-stressed by the glass insert, then pops out (direct activation). The alarm is immediately transmitted to the control panel.



To reset the manual call points after an alarm, a new glass insert must be inserted. With FDM223H, the locking lever on the switching unit must also be reset.

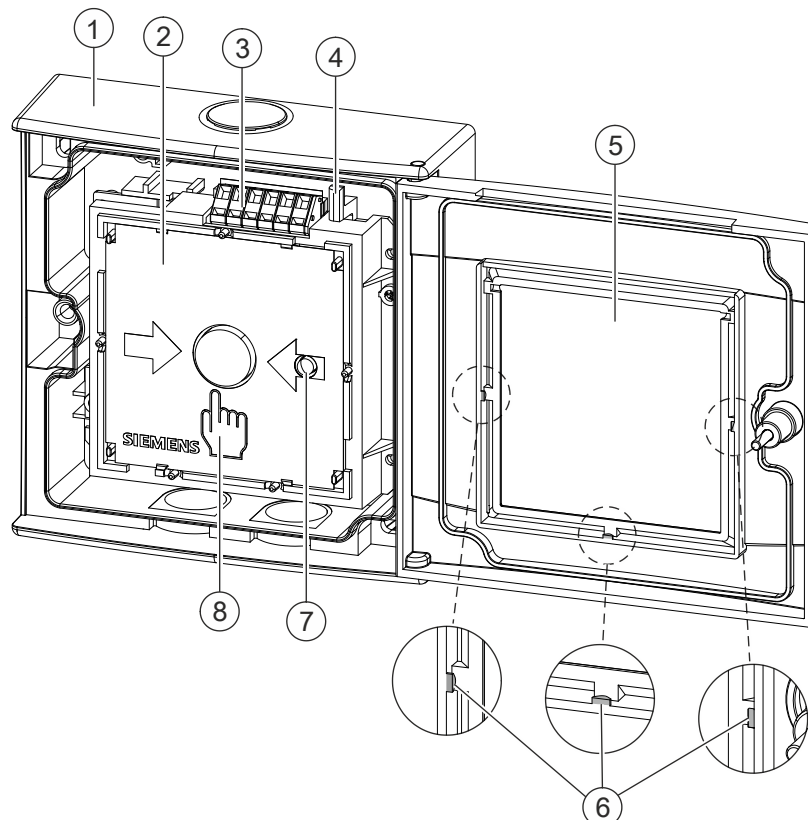

Figure 4: Manual call point FDM223H with housing FDMH292-R with open door

- | | | | |
|---|----------------|---|-----------------------------|
| 1 | Housing | 5 | Glass insert |
| 2 | Switching unit | 6 | Guides for the glass insert |
| 3 | Spring clips | 7 | Internal alarm indicator |
| 4 | Locking lever | 8 | Alarm button |

3.2.3 Connections

The manual call points FDM223/FDM224 and FDM223H/FDM224H both have six spring clips on the switching unit for the detector line and connecting external alarm indicators.

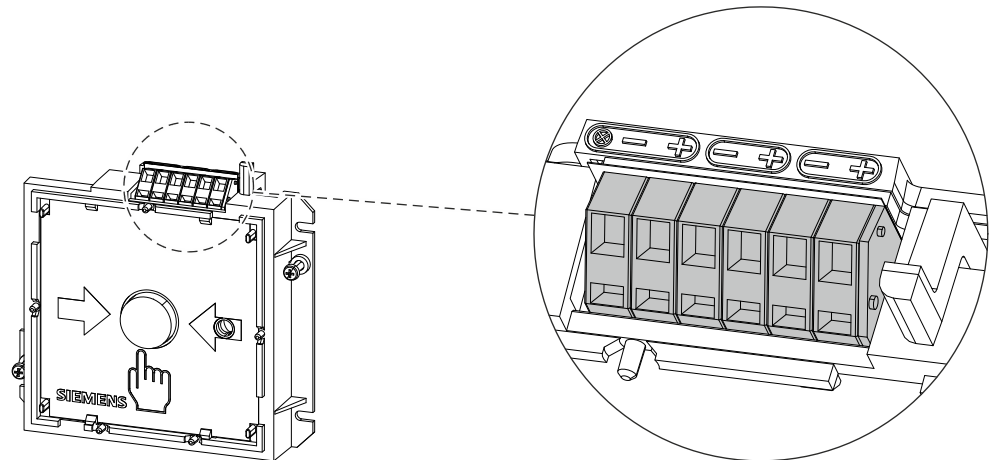

Figure 5: Switching unit with spring clips

3.2.4 Indication elements

An LED is built into the switching unit FDME223/FDME224 as an internal alarm indicator.

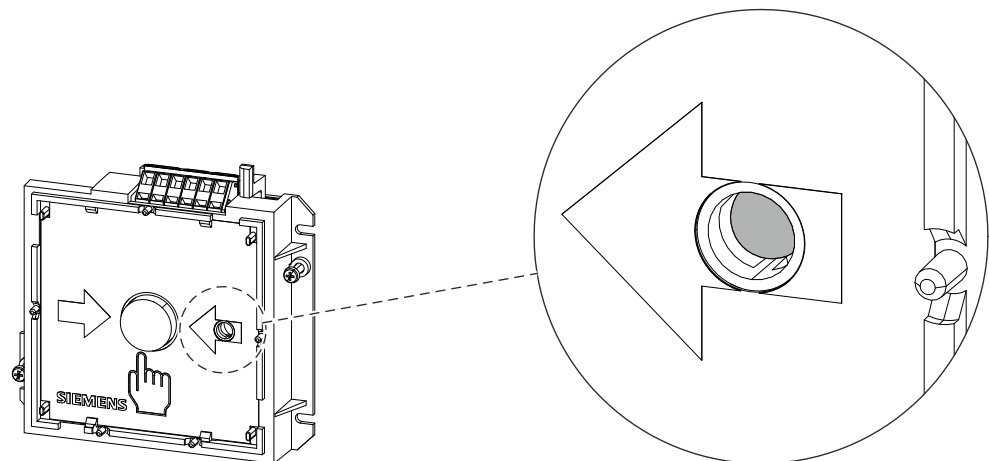

Figure 6: Example of a switching unit with an alarm indicator

See also

- Internal alarm indicator [→ 19]

3.3 Function

3.3.1 Danger levels

The manual call point can transmit the following danger levels to the control panel:

Danger level	Meaning
0	Normal state, no danger
3	Alarm

The evaluation of the danger level and the resulting measures (e.g. activation of remote transmission) are configured on the control panel.

3.3.2 Internal alarm indicator

The LED indicator of the alarm indicator has the following meanings:

LED indication	Meaning
Off	<ul style="list-style-type: none">• Normal condition
Green Flashes once per second	<ul style="list-style-type: none">• Test mode is active
Red Flashes once per second	<ul style="list-style-type: none">• Localization is active o r• Alarm is triggered
Red and green alternating Flashes twice per second	<ul style="list-style-type: none">• Alarm is triggered/localization is active a n d• Test mode is active

See also

📖 Indication elements [→ 18]

3.3.3 Line separator

All FDnet/C-NET devices are equipped with a line separator.

The FDnet/C-NET device is equipped with electronic switches which isolate the defective part in case of a short-circuit on the FDnet/C-NET detector line. The rest of the detector line remains serviceable. On a loop line, all FDnet/C-NET devices remain fully functional after a single short-circuit.

3.3.4 Test mode

A test mode must be set on the control panel to test the manual call points. When in test mode, alarms from the manual call points are not forwarded by the control panel.

See also

📖 Checking function [→ 39]

3.3.5 Interface to service devices

A proximity interface (MC link) is available for commissioning and maintenance in order to communicate with the detector exchanger and tester FDUD292 and the intelligent detector tester FDUD293.

You will find additional information in documents 007227 and 009718.

See also

 Applicable documents [→ 7]

3.3.6 Diagnosis levels

The manual call point monitors its operation largely autonomously.

The following diagnosis levels are derived from the different control measurements:

- Normal
- Replacement necessary
- Fault

For details, see table below.

When an error occurs which impairs the correct functionality of the device, a fault message is reported to the control panel.

To remedy the cause, additional information is available in the manual call point.

This can be displayed by the detector exchanger and tester FDUD292 or the intelligent detector tester FDUD293, for example.

You will find additional information in documents 007227 and 009718.

Information displayed on the detector exchanger and tester	Meaning	Measures
'No deviation'	Normal, no fault is present The manual call point is fully functional	None
'needed excha.' ¹	Replacement necessary Key monitoring outside the tolerance range	Replace manual call point
Other fault message ²	Fault present <ul style="list-style-type: none"> • Alarming no longer guaranteed • Key monitoring outside the tolerance range or malfunctioning due to external influences 	Replace manual call point
	Supply error	<ul style="list-style-type: none"> • Check detector line voltage • Replace manual call point
	Software error (Watchdog error)	Replace manual call point
	Memory error	Replace manual call point
	Communication error between the manual call point and the control panel	Remedy cause

¹ The information displayed on the detector exchanger and tester is always in English; no translation into the corresponding language.

² This status can be displayed together with other statuses, e.g. 'needed excha.' (replacement necessary).

See also

 Applicable documents [→ 7]

3.3.7 Behavior in degraded mode

Applicable for the FDnet/C-NET:

When the main processor of the fire control panel fails, the control panel works in degraded mode operation. Depending on the control panel type, the fire control panel can continue to perform the most important alarming and signaling functions in degraded mode operation.

Behavior of control panels that support degraded mode operation:

- Alarming is still ensured in degraded mode operation. However, in degraded mode only collective alarming is possible. This means that in the event of an alarm, it is possible to identify the FDnet/C-NET detector line but not the exact location of the detector triggering the alarm.

Degraded mode operation on the FDnet/C-NET is not supported in the same way by all control panels. The information in the 'List of compatibility' and in the corresponding control panel documentation must be taken into account during project planning.

3.3.8 Line tester

The line tester FDUL221 is able to recognize and localize the following errors on the FDnet/C-NET:

- Wiring error
- Open line
- Short-circuit
- Ground fault

In addition, the line tester recognizes the devices connected to the FDnet/C-NET detector line.

You will find more information in document 008250.

See also

 Applicable documents [→ 7]

3.4 Accessories

3.4.1 Housing for manual call point FDMH293-x

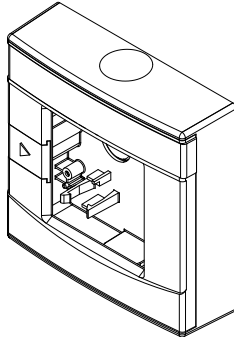

- Housing for use indoors
- Available in the colors red, yellow, green, and blue
- Larger dimensions than the housing FDMH297-R
- Compatible with:
 - Switching unit FDME223
 - Switching unit FDME224
- Order number:
 - FDMH293-R A5Q00004023 (~RAL 3000 flame red)
 - FDMH293-Y: A5Q00004908 (~RAL 1023 traffic yellow)
 - FDMH293-G: A5Q00004911 (~RAL 6024 traffic green)
 - FDM293-B: A5Q00004909 (~RAL 5005 signal blue)
 - FDMH293-O: S54311-F2-A1 (~RAL 2011 deep orange)

3.4.2 Housing for manual call point FDMH297-R

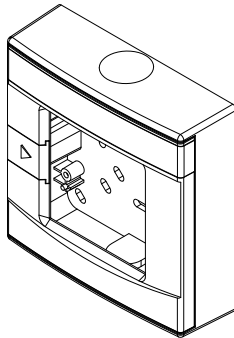

- Housing optimized for the migration of old manual call points in wall hydrants, for example. Height and width of housing same as old SIGMASYS manual call points.
- Smaller dimensions than the housing FDMH293-x
- Compatible with:
 - Switching unit FDME223
 - Switching unit FDME224
- Order number: S54311-B7-A1

3.4.3 Housing for manual call point FDMH292-R

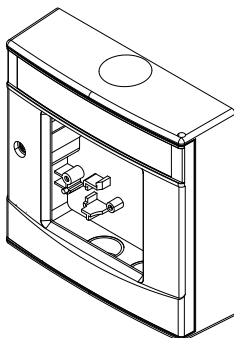

- Housing for use indoors and outdoors
- Very robust housing design made from fiberglass-reinforced thermoplast
- Compatible with:
 - Switching unit FDME223
 - Switching unit FDME224
- Order number: A5Q00005525

3.4.4 Key DMZ1195

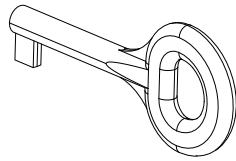

- For opening doors on manual call points
- Compatible with:
 - Manual call point FDM223
 - Manual call point FDM224
 - Radio manual call point FDM273
- Order number: BPZ:4851910001

3.4.5 Glass insert DMZ1196-AC

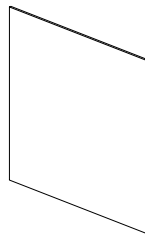

- For alarm activation and protection against soiling
- Compatible with:
 - Manual call point FDM223
 - Manual call point FDM224
 - Manual call point FDM223H
 - Manual call point FDM224H
 - Radio manual call point FDM273
- Order number: BPZ:4942050001

See also

- 📄 Replacing the glass insert [→ 45]

3.4.6 Protective cover DMZ1197-AC

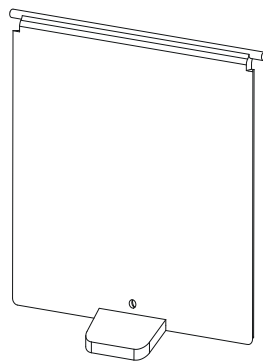

- For protection against unintended alarm activation
- Compatible with:
 - Manual call point FDM223
 - Manual call point FDM224
 - Manual call point FDM223H
 - Manual call point FDM224H
 - Radio manual call point FDM273
- Order number: BPZ:5223550001

See also

- 📄 Installing the protective cover [→ 35]

3.4.7 Seal DMZ1197-AD

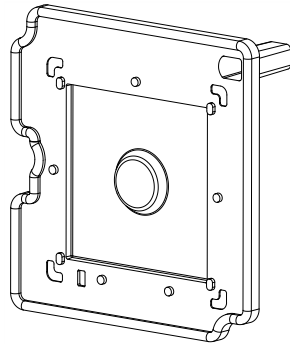

- For using manual call points in areas where there is a risk of splash water
- Increases the IP protection category of the manual call points
- Compatible with:
 - Manual call point FDM223
 - Manual call point FDM224
 - Manual call point FDM223H
 - Manual call point FDM224H
 - Radio manual call point FDM273
- Not compatible with the housing FDMH297-R
- Order number: BPZ:5470680001

See also

📄 Installation [→ 31]

3.4.8 Seal FDMP223



- Increases the protection category of the manual call point to IP44
- Compatible with:
 - Manual call point FDM223H
 - Manual call point FDM224H
 - Manual call point FDM223-Ex
 - Housing FDMH292-R
- Order number: S54311-F10-A1

3.4.9 Auxiliary terminal

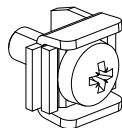

- For connecting cables in insulated manner, e.g. cable shielding
- For housings made from plastic
- Compatible with:
 - Housing FDCH221
 - FDMH2xx housing
- Order number: BPZ:4074540001

3.4.10 Cable gripper (2-hole)

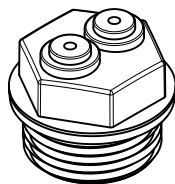

- For inserting two cables into one housing
- For cable diameters of up to 7.8 mm
- Male thread M20 x 1.5
- Compatible with:
 - Housing FDMH231-S-R
 - Housing FDMH292-x
 - Housing FDMH293-x
 - Housing FDMH297-R
 - Housing HA230
- Order number: A5Q00010055

3.4.11 M20 x 1.5 metal cable gland

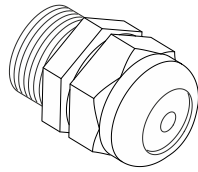

- For introducing a cable into a housing
- For cable diameters of 3.5...5.5 mm
- Temperature range: -40...+100 °C
- Allows for increased IP protection
- Compatible with:
 - M20 x 1.5 metal counter nut
 - Housing FDMH231-S-R
 - Housing FDMH292-x
 - Housing FDMH293-x
 - Housing FDMH297-R
 - Housing FDCH221
 - Manual call point FDM243H
 - Air sampling smoke detection kit FDBZ290
 - Base deep (wall mounting) FDB227-x
- Order number: A5Q00004478

4 Planning

4.1 Compatibility FDnet/C-NET

Compatible with control panels that support the FDnet/C-NET detector line.

Detector line	Control panel			
	FC20xx	FC72x	SIGMASYS	AlgoRex
FDnet	X	-	X	X
C-NET	-	X	-	-

X = compatible

- = not compatible

You will find detailed information in the 'List of compatibility'.

See also

 Applicable documents [→ 7]

4.2 Fields of application

The manual call points are intended for use in places where a fire can be detected by people who can manually trigger an alarm.

4.3 Mounting site

The manual call points must be installed in easily accessible places at a height of 0.9...1.6 m on an even surface.



Observe the country-specific regulations for the exact mounting height!

4.4 Environmental influences

If the devices are used in industrial applications, consultation with the project manager is required, since plastics do not withstand certain environmental conditions.

The following factors must be taken into consideration:

- Chemicals
- Temperature
- Moisture

5 Mounting / Installation

The manual call points are mounted and installed in three steps:

1. Preparation (see the chapter 'Preparation [→ 27]')
2. Installation (see the chapter 'Installation')
3. Electrical connection (see the chapter 'Installation')

See also

- 📄 Installing the stickers [→ 36]

5.1 Preparation

Depending on the cabling (surface-mounted cable entry or recess-mounted cable entry), the housing must be prepared for cable entry.

Manual call points FDM223 and FDM224 (housing FDMH293-x or FDMH297-R)

1. Push the keyhole cover to the right.
 2. Open the door with the key supplied.
 3. **NOTICE! Keep the key in a safe place.**
 4. Push the keyhole cover back into place.
 5. Determine the cable entry opening(s) in the housing.
 - From above or from below through the cable entry opening provided
 - From the rear through a specified breakout point
- ⇒ The manual call point FDM223/FDM224 is now prepared for mounting.

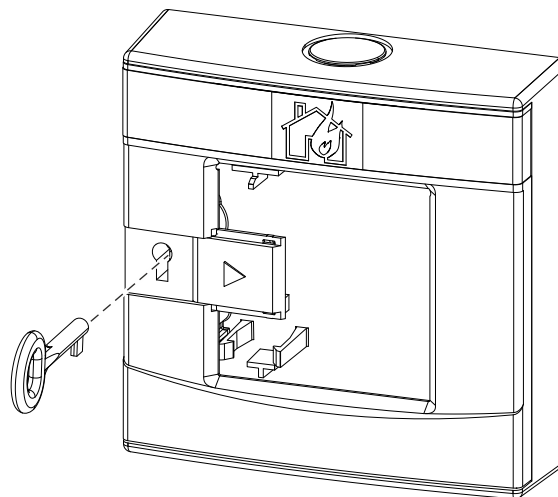

Figure 7: Opening the door of manual call points FDM223 and FDM224

Manual call points FDM223H and FDM224H (housing FDMH292-R)



Cables cannot be inserted through the back of the housing for manual call points FDM223H and FDM224H. Cables must enter through one of the cable entry openings provided in the housing.

1. Open the door with the Allen key supplied.
2. **NOTICE! Keep the Allen key in a safe place.**
3. Determine the cable entry opening(s) in the housing.

- Break or cut open the openings for feeding though cables in the cable gripper.
 - Screw the cable gripper into the housing.
4. Seal off cable entry openings that are not required.
- ⇒ The manual call point FDM223H/FDM224H is now prepared for mounting.

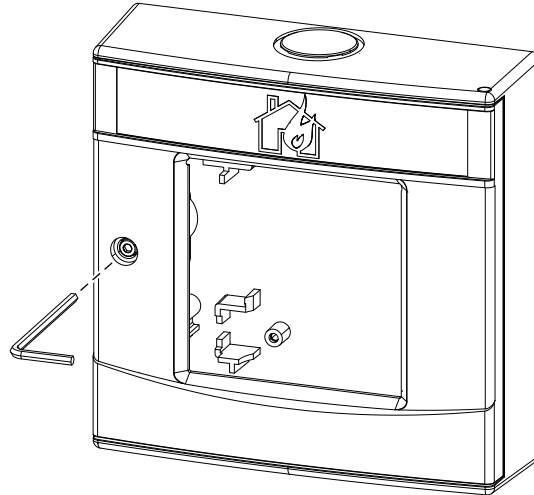

Figure 8: Opening the door of manual call points FDM223H and FDM224H

5.2 Installation



Observe the country-specific regulations for the exact installation height!

Manual call points FDM223 and FDM224 (housing FDMH293-x or FDMH297-R)

- ▷ The manual call point FDM223/FDM224 is prepared for installation. See the chapter 'Preparing the housing'.
 1. Secure the housing at a height of 0.9...1.6 m on an even surface.
 - If you are using housing FDMH293-x: In wet areas, only use the screw holes marked by arrows (see diagram below).
 - Housing FDMH297-R may not be used in wet areas.
 2. Pull the cables through the entry opening(s) into the housing.
 - Cable entry from the rear of the housing is only permitted for housing FDMH297-R.
 - In wet areas, use metal cable glands M20 x 1.5 (accessories).
- ⇒ The manual call point FDM223/FDM224 is now prepared for electrical connection.

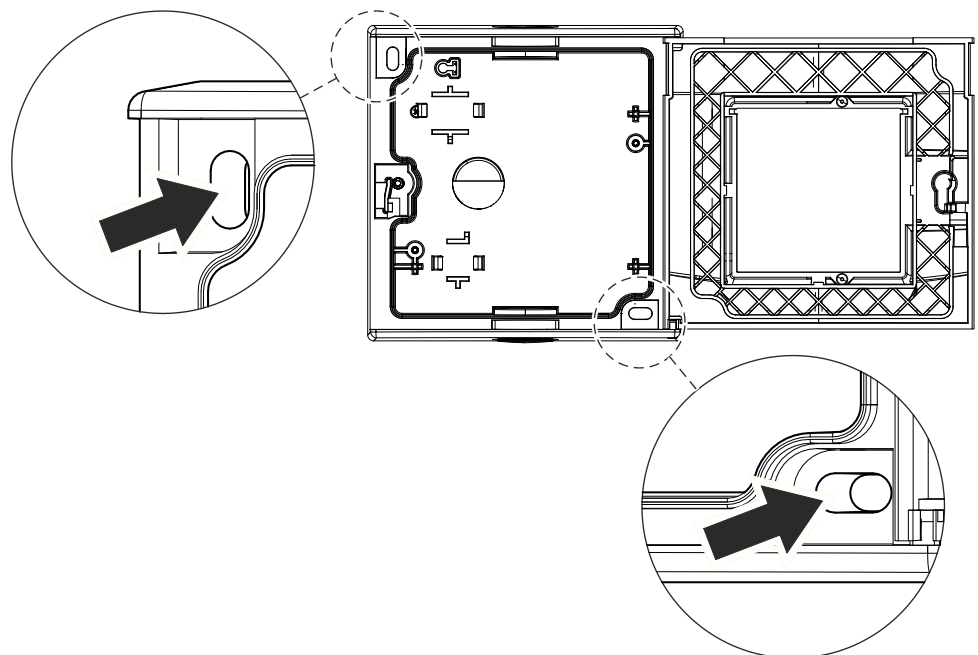

Figure 9: Screw holes in housing FDMH293-x

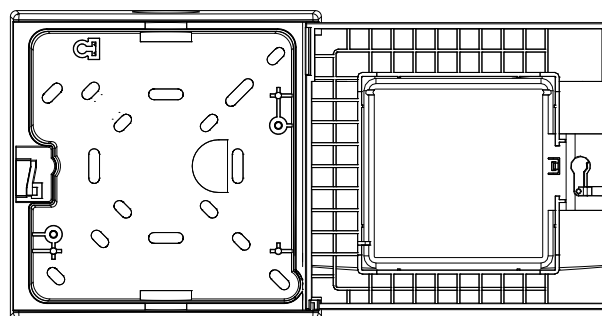

Figure 10: Housing FDMH297-R with breakout points for cable entries and screws (cable entries and screw holes are compatible with old housings)

Manual call points FDM223H and FDM224H (housing FDMH292-R)

- ▷ The manual call point FDM223H/FDM224H is prepared for installation. See the chapter 'Preparation [→ 27]'.
1. Secure the housing at a height of 0.9...1.6 m on an even surface.
– Only use the screw holes marked with arrows (see diagram below).
2. Pull the cables into the housing through the openings in the cable gripper.
– In wet areas, use metal cable glands M20 x 1.5 (accessories) instead of cable grippers.
⇒ The manual call point FDM223H/FDM224H is now prepared for electrical connection.

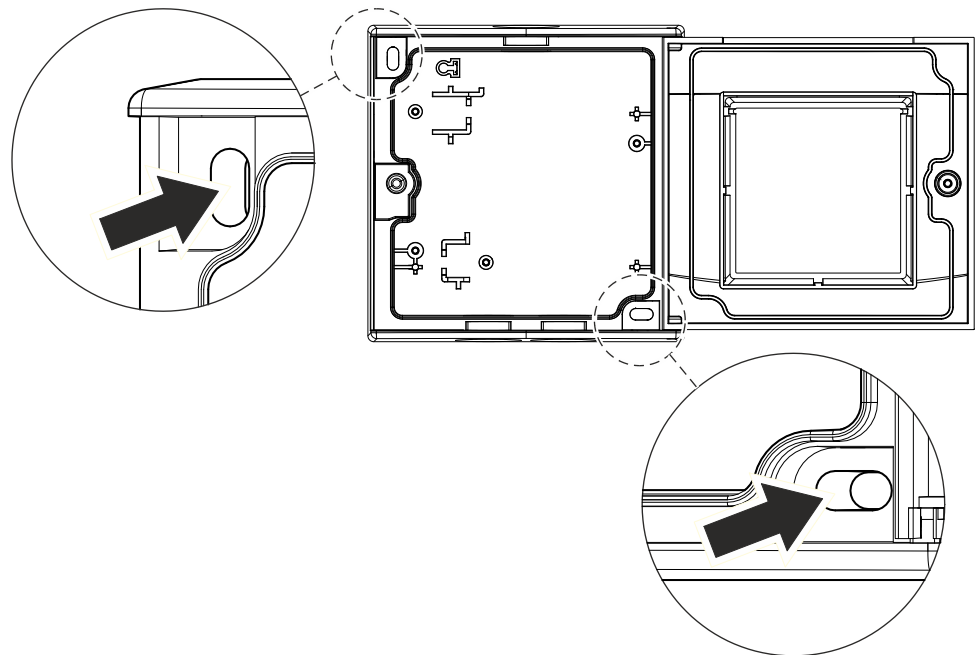



Figure 11: Screw holes in housing FDMH292-R

5.3 Installation

Notes on work on electrical installations

	<p>⚠ CAUTION</p>
	<p>Electrical voltage on lines Risk of injury due to electric shock</p> <ul style="list-style-type: none"> • During mounting and installation work, electrical voltage must not be applied to the lines.

	<p>⚠ WARNING</p>
	<p>Deactivated manual call points prevent alarms from being transmitted. The alarm is not triggered.</p> <ul style="list-style-type: none"> • Mark deactivated manual call points or those which are not fully functional with the notice 'NOT IN USE'!

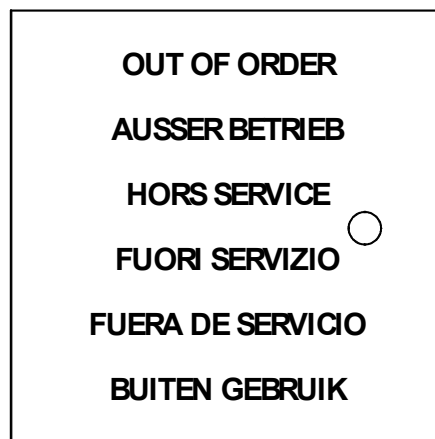

Figure 12: 'NOT IN USE' label



Note the positive and negative poles.

Only connect one wire per terminal. This is the only way to ensure the connection is failure-free for the entire service life of the device.

Connection diagram

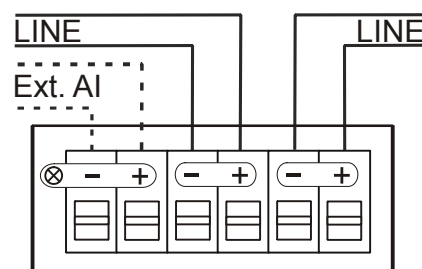

Figure 13: Connection diagram for manual call points FDM223/FDM224 and FDM223H/FDM224H

Connecting the manual call points

- ▷ The manual call point is prepared for electrical connection. See chapters 'Preparation [→ 27]' and 'Installation [→ 29]'.
1. Connect the feed line to the terminals in the switching unit (3) or (7), in accordance with the connection diagram.
 2. If using shielded cables:
 - **NOTICE! The shielding must not touch any external potentials.**
 - Connect the shielding for the detector line cables (LINE) to an auxiliary terminal (accessories) in the housing.
 - Connect the shielding of the external alarm indicator cable with the positive pole of the external alarm indicator connection.
 3. **NOTICE! Avoid crushing the cables! Pay attention to the feed line when inserting the switching unit (3) or (7) into the housing (6).**
 4. Insert the switching unit (3) or (7) into the housing (6) with the terminals facing upward.
 5. Secure the switching unit (3) or (7) with two screws (2).
 6. Use a seal DMZ1197-AD (1) in wet areas (accessories).
 - During installation, pay attention to the position of the rubber recess.
 - Check whether the sealing lip is correctly attached to the edge of the housing after installation.
 7. Close the housing (6) with the door.
- ⇒ The manual call point is now electrically connected.



Seal DMZ1197-AD cannot be installed if you are using housing FDMH297-R.

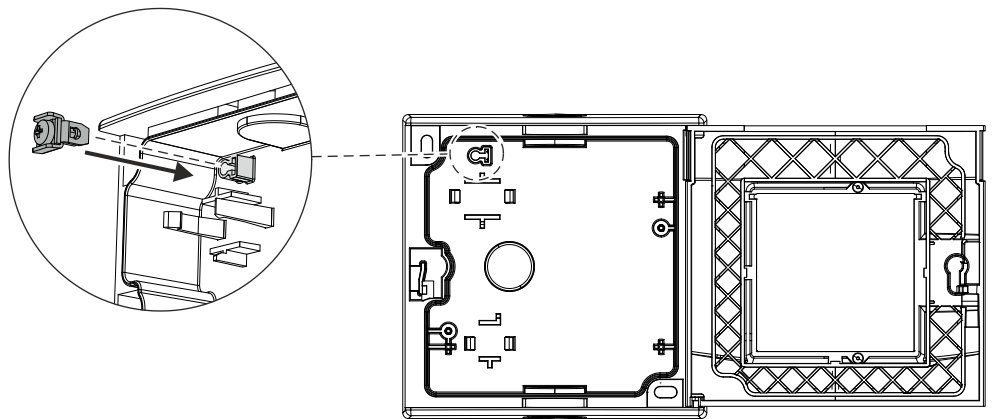

Figure 14: Installing an auxiliary terminal in housing FDMH293-x

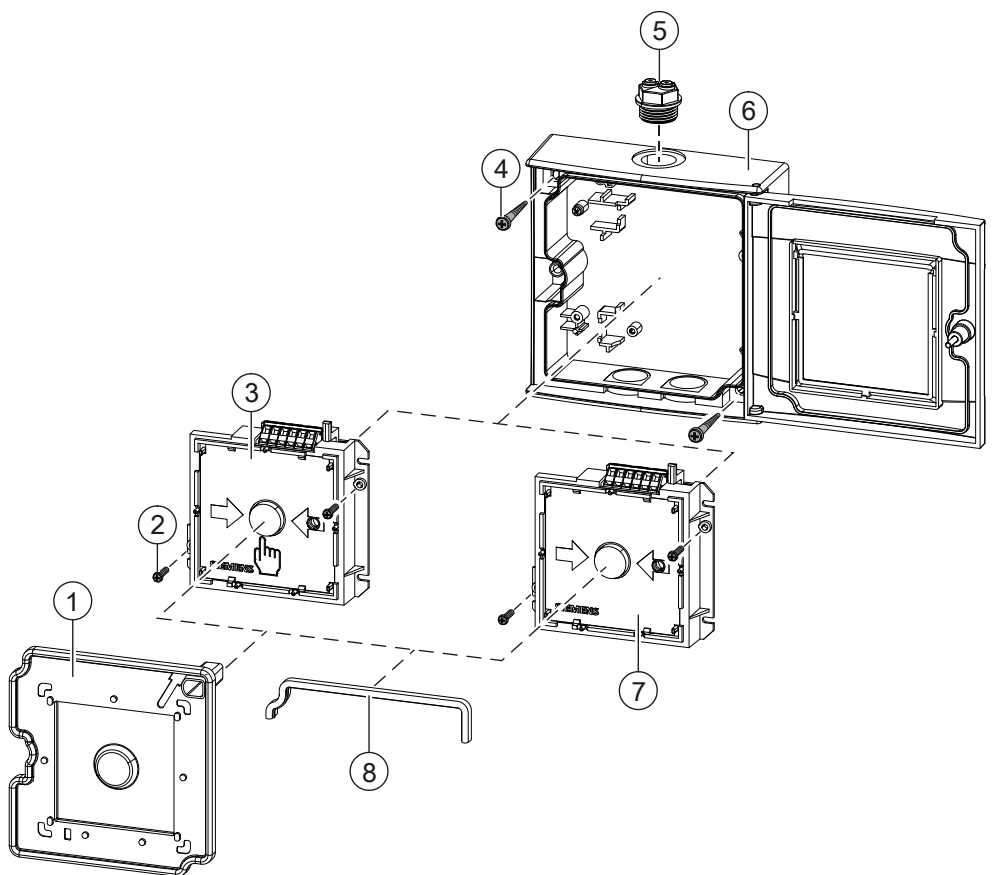

Figure 15: Installing manual call points FDM223/FDM224 and FDM223H/FDM224H

- | | | | |
|---|------------------------|---|------------------------|
| 1 | Seal DMZ1197-AD | 5 | Cable gripper |
| 2 | Screw | 6 | Housing |
| 3 | Switching unit FDME223 | 7 | Switching unit FDME224 |
| 4 | Screw | 8 | Seal FDMP223 |

5.3.1 Mounting the seal FDMP223

- ▷ The manual call point is electrically connected.
- 1. Install the seal FDMP223 (1) in the housing FDMH292-R.
- 2. Check that the seal envelops the sealing lip (2) of the housing.

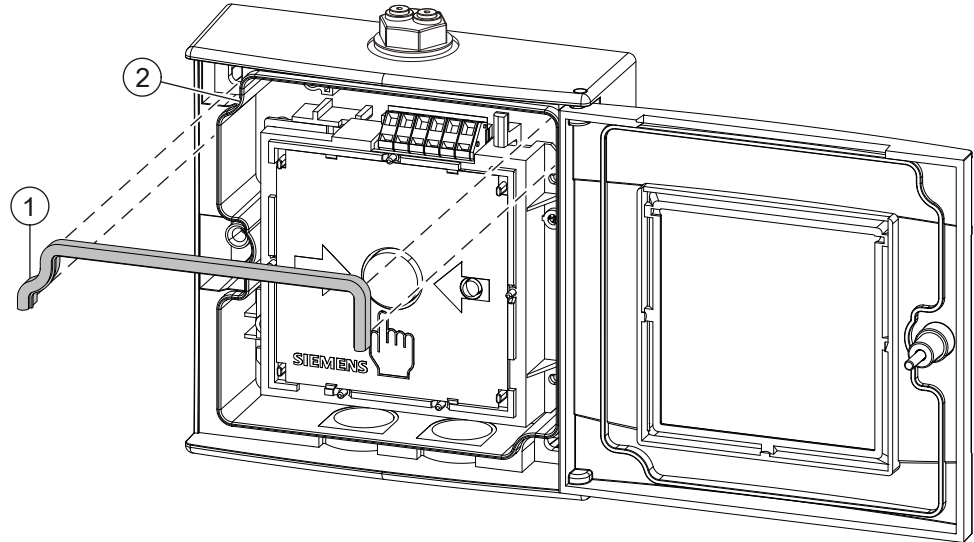

Figure 16: Mounting the seal FDMP223

5.4 Installing the protective cover

If a protective cover (accessories) is used, proceed as follows:

- ▷ A compatible protective cover is available. See the chapter 'Accessories [→ 22]'.
 1. Open the door of the manual call point.
 2. Remove the glass insert. See the chapter 'Replacing the glass insert [→ 45]'.
 3. Guide the protective cover (1) through the opening in the door from the front, as shown in the diagram.
 4. Insert the pivot pins (2) for the protective cover (1) in the two recesses on the rear side of the door, as shown in the diagram.
 5. Install the glass insert. See the chapter 'Replacing the glass insert [→ 45]'.
 6. Close the door of the manual call point.

⇒ The protective cover is inserted.

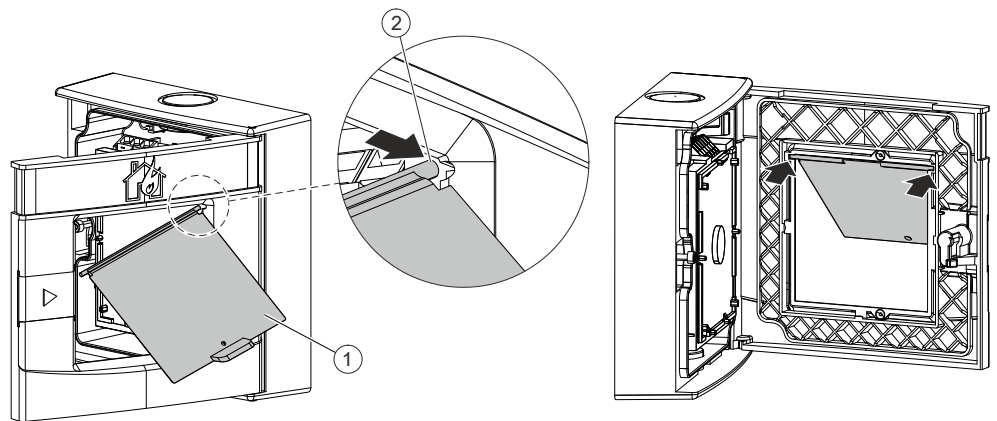

Figure 17: Example of installing protective cover DMZ1197-AC on a manual call point

- 1 Protective cover DMZ1197-AC 2 Pivot pin

See also

- 📄 Protective cover DMZ1197-AC [→ 23]
- 📄 Installation [→ 31]

5.5 Installing the stickers



Only use the stickers if local regulations require the manual call point to be labeled in this way.

- ▷ Appropriate stickers that are printed on both sides are available.
 1. Open the door and lift the transparent cover to the side.
 2. Insert the stickers so the desired side is displayed.
 3. Attach the transparent cover so that it snaps into place at the side.
- ⇒ The manual call point has a new label.

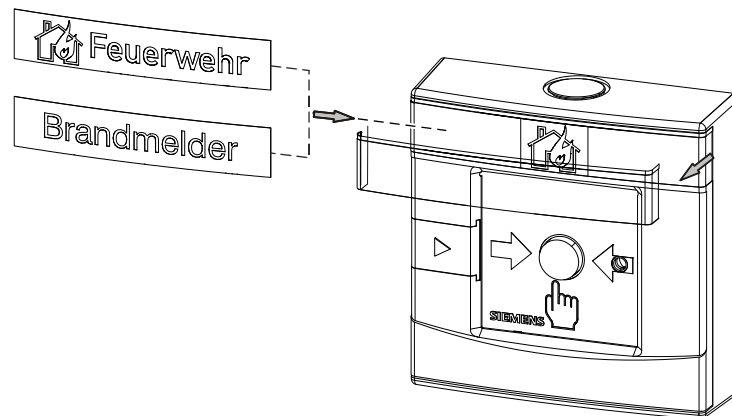

Figure 18: Attaching the stickers to a manual call point FDM223

5.6 Attaching the window sign

If you are using housing FDMH292-R, the printed window sign may be covered with a self-adhesive sticker that has been supplied.



Observe local regulations for using the self-adhesive sticker! Only use the self-adhesive sticker supplied if local regulations require the manual call point to be labeled in this way.

- ▷ The manual call point must be labeled with 'Fire detector' or 'Fire brigade'.
 1. Clean the adhesive surface on the door.
 2. Stick a self-adhesive sticker to the door of the manual call point as shown in the diagram below.
- ⇒ The manual call point has a new label.

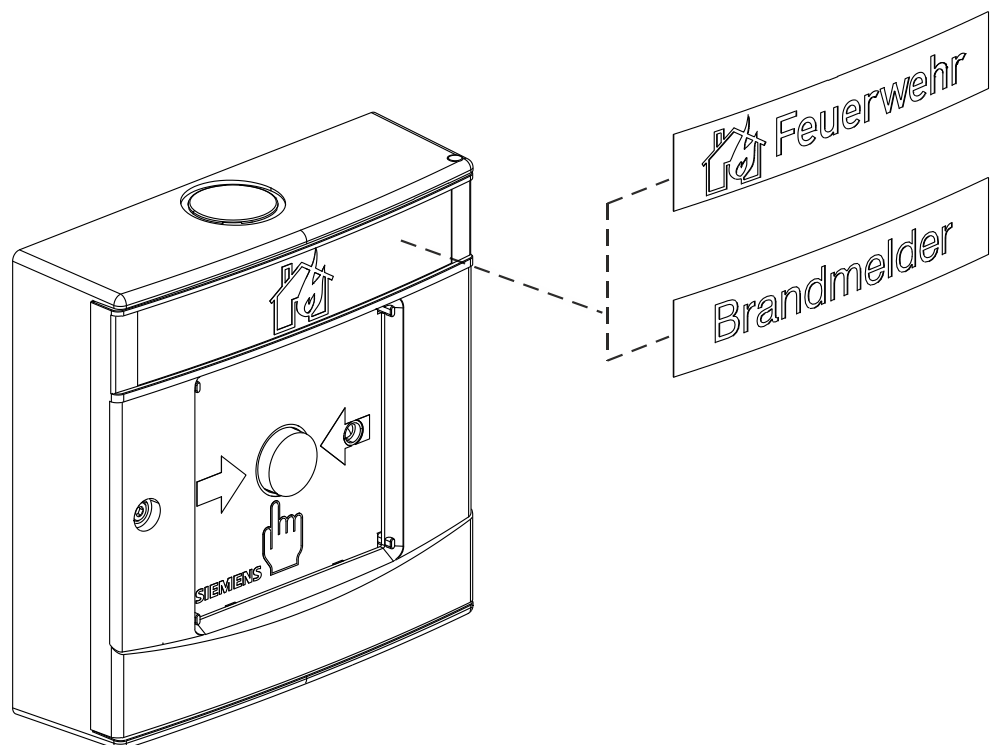

Figure 19: Attaching a self-adhesive sticker to the housing FDMH292-R

See also

- 📄 Installation [→ 31]

6 Commissioning

The devices are commissioned via the control panel. The exact procedure is described in the control panel documentation.

Conduct a performance check once commissioning is complete.

6.1 Localization and device testing

The manual call points have an internal alarm indicator. This internal alarm indicator may also be activated from the control panel for localization and device testing.

The LED indicator of the alarm indicator has the following meanings:

LED indication	Meaning
Off	<ul style="list-style-type: none"> Normal condition
Green Flashes once per second	<ul style="list-style-type: none"> Test mode is active
Red Flashes once per second	<ul style="list-style-type: none"> Localization is active or Alarm is triggered
Red and green alternating Flashes twice per second	<ul style="list-style-type: none"> Alarm is triggered/localization is active and Test mode is active

See also

 Indication elements [→ 18]

6.2 Checking function

Manual call point FDM223

- ▷ The manual call point is installed and electrically connected. See the chapter 'Installation [→ 31]'.
1. Set the detector line to 'Test' on the control panel.
 2. Push the keyhole cover to the right.
 3. Open the door of the manual call point with the key.
 4. Pull out the key.
 5. Push the keyhole cover back into place.
 6. Press the alarm button.
⇒ The alarm signal is transmitted.
 7. Check whether an alarm is displayed on the fire control panel.
 8. Push the black locking lever (1) at the top right of the switching unit to the right until it clicks.
⇒ The alarm button is now protruding by approx. 5 mm.
 9. Close the door of the manual call point.
⇒ The manual call point is ready for operation again.
 10. Set the detector line to 'Normal operation' on the control panel.
⇒ The detector line is ready for operation again.

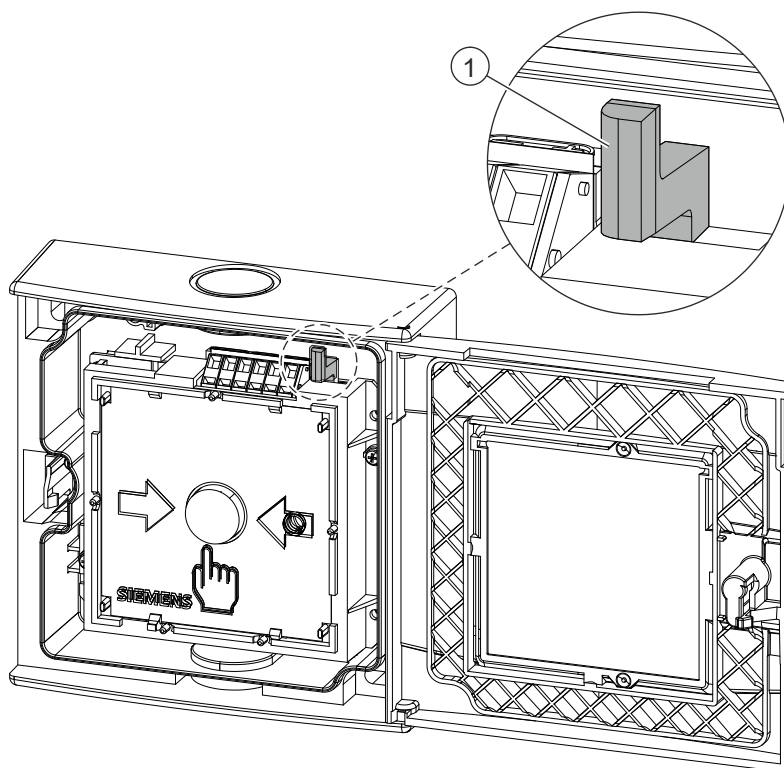

Figure 20: Resetting manual call point FDM223

- 1 Locking lever

Manual call point FDM224

- ▷ The manual call point is installed and electrically connected. See the chapter 'Installation [→ 31]'.
 1. Set the detector line to 'Test' on the control panel.
 2. Push the keyhole cover to the right.
 3. Open the door of the manual call point with the key.
 - ⇒ The alarm signal is transmitted.
 4. Check whether an alarm is displayed on the fire control panel.
 5. Pull out the key.
 6. Push the keyhole cover back into place.
 7. Close the door of the manual call point.
 - ⇒ The manual call point is ready for operation again.
 8. Set the detector line to 'Normal operation' on the control panel.
 - ⇒ The detector line is ready for operation again.

Manual call point FDM223H

- ▷ The manual call point is installed and electrically connected. See the chapter 'Installation [→ 31]'.
1. Set the detector line to 'Test' on the control panel.
 2. Open the door of the manual call point with the Allen key.
 3. Press the alarm button.
⇒ The alarm signal is transmitted.
 4. Check whether an alarm is displayed on the fire control panel.
 5. Push the black locking lever (1) in the top right-hand corner to the right until it clicks.
⇒ The alarm button is now protruding by approx. 5 mm.
 6. Close the door of the manual call point.
⇒ The manual call point is ready for operation again.
 7. Set the detector line to 'Normal operation' on the control panel.
⇒ The detector line is ready for operation again.

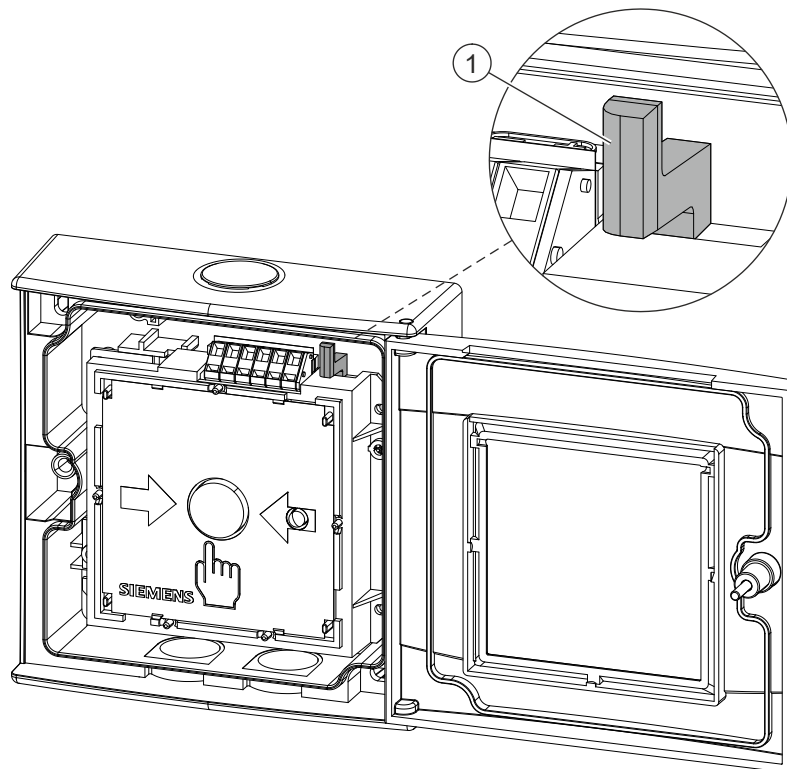

Figure 21: Resetting manual call point FDM223H

- 1 Locking lever

Manual call point FDM224H

- ▷ The manual call point is installed and electrically connected. See the chapter 'Installation [→ 31]'.
 1. Set the detector line to 'Test' on the control panel.
 2. Open the door of the manual call point with the Allen key.
 - ⇒ The alarm signal is transmitted.
 3. Check whether an alarm is displayed on the fire control panel.
 4. Close the door of the manual call point.
 - ⇒ The manual call point is ready for operation again.
 5. Set the detector line to 'Normal operation' on the control panel.
 - ⇒ The detector line is ready for operation again.

7 Maintenance / Repair

7.1 Resetting after an alarm

After an alarm is activated, the manual call point must be reset to a state in which it is ready for operation.

Reset the detector to a state of operational readiness as follows:

FDM223 and FDM223H

- ▷ The glass insert has been shattered and the alarm button is pressed.
- 1. Open the door of the manual call point. See the chapter 'Preparation [→ 27]'.
 2. **⚠ CAUTION! Sharp remains of glass. Risk of cutting injuries when removing the remains of the glass insert. Remove the remains of the glass carefully.**
 3. Remove all the remains of the old glass insert.
 4. Insert a new glass insert. See the chapter 'Replacing the glass insert [→ 45]'.
 5. Push the black stopping lever in the upper right corner of the switching unit to the right until it clicks.
 - ⇒ The alarm button is now protruding by approx. 5 mm.
 6. Close the door of the manual call point.
 7. Carry out a performance check. See the chapter 'Checking function [→ 39]'.
 - ⇒ The manual call point is ready for operation again.

FDM224 and FDM224H

- ▷ The glass insert has been shattered and the alarm button is unstressed.
- 1. Open the door of the manual call point. See the chapter 'Preparation [→ 27]'.
 2. **⚠ CAUTION! Sharp remains of glass. Risk of cutting injuries when removing the remains of the glass insert. Remove the remains of the glass carefully.**
 3. Remove all the remains of the old glass insert.
 4. Insert a new glass insert. See the chapter 'Replacing the glass insert [→ 45]'.
 5. Close the door of the manual call point.
 - ⇒ Closing the door pre-stresses the alarm button in the switching unit.
 6. Carry out a performance check. See the chapter 'Checking function [→ 39]'.
 - ⇒ The manual call point is ready for operation again.

7.2 Status query

Status query on the detector exchanger and tester

Each manual call point for FDnet/C-NET features a proximity interface (MC link). Using this interface, it is possible to read out data from the device in a proximity method over short distances with the detector exchanger and tester FDUD292 or the intelligent detector tester FDUD293.

To ensure correct communication between the testing device and the manual call point, the alarm indicator on the manual call point must be aligned with a sensor on the testing device. For this purpose, turn the testing device 45 degrees and push it down by approx. 1 cm.

You will find more information in documents 007227 and 009718.

Status query on the control panel

Depending on the authorization level of the user and the control panel type, different actions can be performed from the control panel.

Observe the notices in the control panel documentation.

Document 009052 applies to fire control panels FC20xx.

Document A6V10333448 applies to fire control panels FC72x.

7.3 Performance check

The devices are automatically subjected to a performance check during the self-test. Nevertheless, it is necessary to check the devices on site at regular intervals.

Recommendation:

- Check the devices every year.
- Replace heavily soiled or damaged devices.

No other special maintenance work is necessary.

You will find more detailed information in the fire detection system documentation.

See also

 Checking function [→ 39]

7.4 Replacing the glass insert

Manual call points FDM223H and FDM224H

The glass insert is square-shaped and can be inserted in any direction.



CAUTION

Risk of cutting injuries when removing the glass fragments
Remove the glass fragments carefully

To replace the glass insert, proceed as follows:

- ▷ The door of the manual call point is open. See the chapter 'Preparation'.
- 1. Remove all the remains of the old glass insert.
- 2. Insert the new glass insert between the guides (1) and slide it down as far as the stop behind the retainer (2).
 - You may need to manipulate the glass insert slightly before it will slide into the retainer (2).
 - ⇒ The glass is fitted in the door.
- 3. Check the function of the manual call point.
- 4. Close the door.
- ⇒ The glass insert has been replaced.

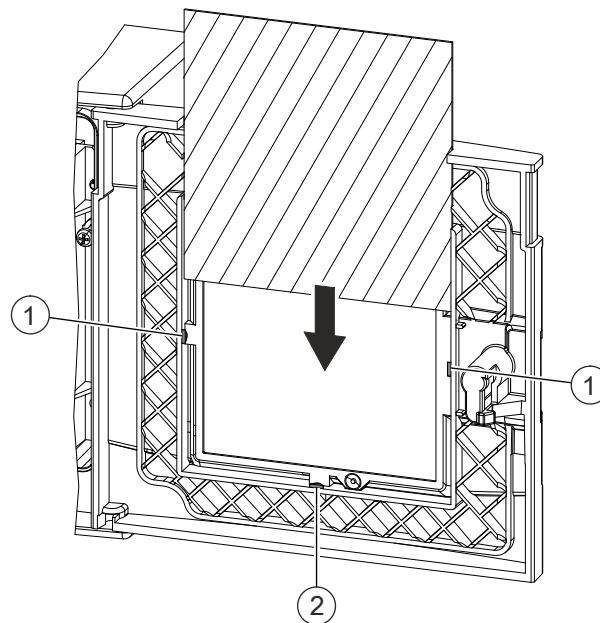

Figure 22: Replacing the glass insert

1 Guides

2 Holder

Manual call points FDM223H and FDM224H

The glass insert is square-shaped and can be inserted in any direction.



CAUTION



Risk of cutting injuries when removing the glass fragments

Remove the glass fragments carefully

To replace the glass insert, proceed as follows:

- ▷ The door of the manual call point is open. See the chapter 'Preparation [→ 27]'.
 1. Remove all the remains of the old glass insert.
 2. Insert the new glass insert between the guides (1) and slide it down as far as the stop behind the retainer (2).
 - You may need to manipulate the glass insert slightly before it will slide into the retainer (2).
 - ⇒ The glass is fitted in the door.
 3. Check the function of the manual call point.
 4. Close the door.
 - ⇒ The glass insert has been replaced.

See also

-  Glass insert DMZ1196-AC [→ 23]
-  Checking function [→ 39]

8 Specifications

8.1 Technical data

You will find information on approvals, CE marking, and the relevant EU directives for this device (these devices) in the following document(s); see 'Applicable documents' chapter:

- Document 007001
- Document 008345

Detector line	Operating voltage	DC 12...33 V
	Operating current (quiescent)	200 μ A
	Maximum current connection factor	1
	Quiescent current connection factor	1
	Address connection factor	1
	Separator connector factor	1
	Protocol	FDnet/C-NET
	System compatibility	See 'List of compatibility'

Line separator	Line voltage:	
	• Nominal	DC 32 V (= V_{nom})
	• Minimum	DC 12 V (= V_{min})
	• Maximum	DC 33 V (= V_{max})
	Voltage at which the line separator opens:	
	• Minimum	DC 7,5 V (= $V_{SO min}$)
	• Maximum	DC 10.5 V (= $V_{SO max}$)
	Permanent current when switches are closed	Max. 1.5 A (= $I_{C max}$)
	Switching current (e.g., in the event of a short-circuit)	Max. 2 A (= $I_{S max}$)
	Leakage current when switches are open	Max. 1 mA (= $I_{L max}$)
Serial impedance when switches are closed	Max. 0.4 Ω (= $Z_{C max}$)	

The line separator is closed via an actuation signal from the control panel. Required line voltage: DC 12...33 V (normal range)

External alarm indicators	Number of external alarm indicators that can be connected	2
	Voltage	DC 10...17 V
	Current	9...15 mA
	Length of line	<ul style="list-style-type: none"> • Max. 30 m with unshielded cables, or when the shielding is connected to the positive pole of the detector base • Max. 5 m, if the shielding is connected to earth

Connections	Detector line and external alarm indicators	Spring clips 0.2...1.5 mm ²
	<ul style="list-style-type: none"> • Design • Conductor cross section 	
	MC link	Proximity interface
Ambient conditions	Operating temperature	-25...+70 °C
	Storage temperature	-30...+75 °C
	Air humidity	≤95 % rel.
	Protection categories (IEC 60529):	
	<ul style="list-style-type: none"> • FDM223/FDM224, in housing FDMH293-x without seal DMZ1197-AD 	IP41
	<ul style="list-style-type: none"> • FDM223/FDM224, in housing FDMH297-R without seal DMZ1197-AD 	IP41
	<ul style="list-style-type: none"> • FDM223/FDM224, in housing FDMH293-x with seal DMZ1197-AD and metal cable gland 	IP64
	<ul style="list-style-type: none"> • FDM223H/FDM224H, in housing FDMH292-R without seal DMZ1197-AD 	IP41
	<ul style="list-style-type: none"> • FDM223H/FDM224H, in housing FDMH292-R with seal FDMP223 	IP44
	<ul style="list-style-type: none"> • FDM223H/FDM224H, in housing FDMH292-R with seal DMZ1197-AD and metal cable gland 	IP66
	Environmental category according to EN 54-11:	
	<ul style="list-style-type: none"> • FDM223, FDM224 • FDM223H, FDM224H 	In buildings and outdoor areas In buildings and outdoor areas
Electromagnetic compatibility:		
<ul style="list-style-type: none"> • 80 MHz...3 GHz 	50 V/m	
Mechanical data	Design according to EN 54-11:	
	<ul style="list-style-type: none"> • FDM223, FDM223H • FDM224, FDM224H 	Type B (indirect activation) Type A (direct activation)
	Housing material:	
	<ul style="list-style-type: none"> • FDM223/FDM224 in housing FDMH293-x • FDM223/FDM224 in housing FDMH292-R • FDM223H/FDM224H 	Polycarbonate (PC) Polycarbonate (PC) Polyamide (PA)
	Housing colors:	

- FDMH292-R and FDMH297-R ~RAL 3000 flame red
- FDMH293-B ~RAL 5005 signal blue
- FDMH293-Y ~RAL 1023 traffic yellow
- FDMH293-G ~RAL 6024 traffic green
- FDMH293-O ~RAL 2011 deep orange

Dimensions (L x W x H):

- Housing FDMH292-R 134.3 x 134.3 x 42.5 mm
- Housing FDMH293-x 134.3 x 134.3 x 43.2 mm
- Housing FDMH297-R 130 x 130 x 43.2 mm

Weights:

- Housing FDMH292-R 0.302 kg
- Housing FDMH293-x 0.252 kg
- Housing FDMH297-R 0.250 kg
- Switching unit FDME223 0.071 kg
- Switching unit FDME224 0.067 kg
- Glass insert DMZ1196-AC 0.011 kg
- Key DMZ1195 0.001 kg
- Protective cover DMZ1197-AC 0.012 kg
- Sealing for wet areas DMZ1197-AD 0.022 kg
- Seal FDMP223 for FDM223/224 0.003 kg

Standards

European standards

- EN 54-11
- EN 54-17

8.2 Dimensions

Manual call points FDM223 and FDM224, housing FDMH293-x

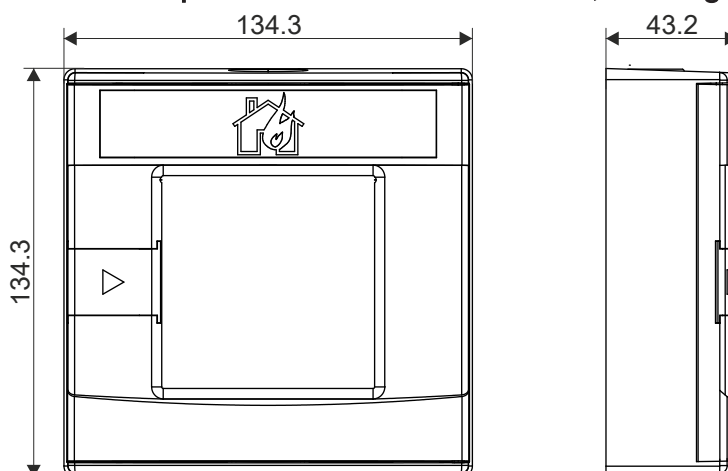

Manual call points FDM223 and FDM224, housing FDMH297-R

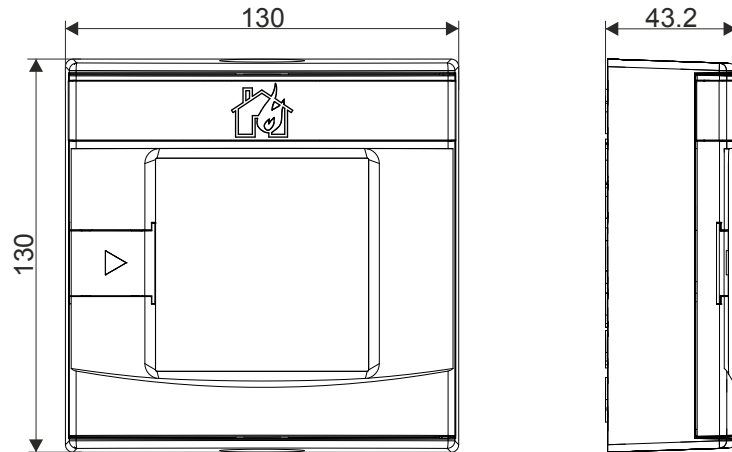

Manual call points FDM223H and FDM224H, housing FDMH292-R

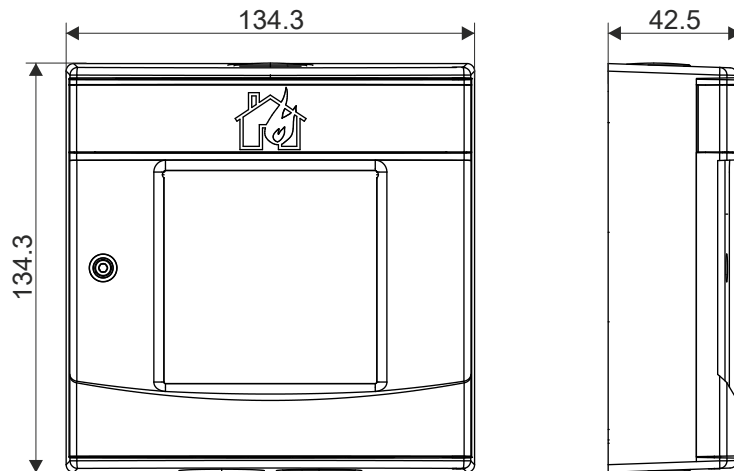

8.3 Master gauges for holes

Manual call points FDM223 and FDM224, housing FDMH293-x

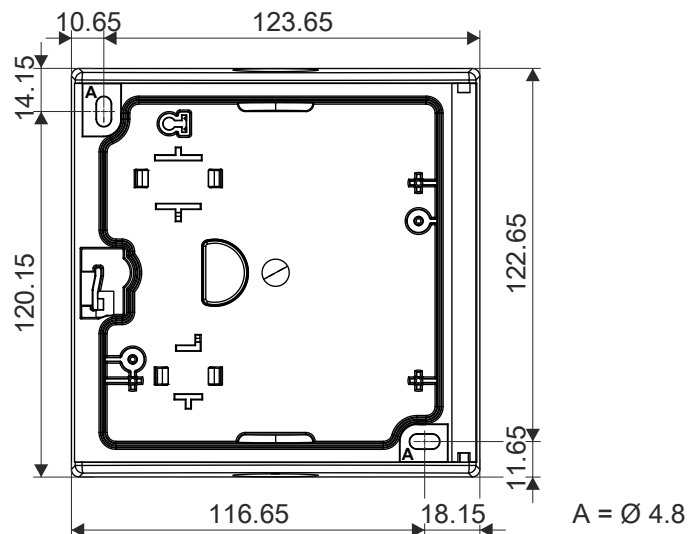

Manual call points FDM223 and FDM224, housing FDMH297-R

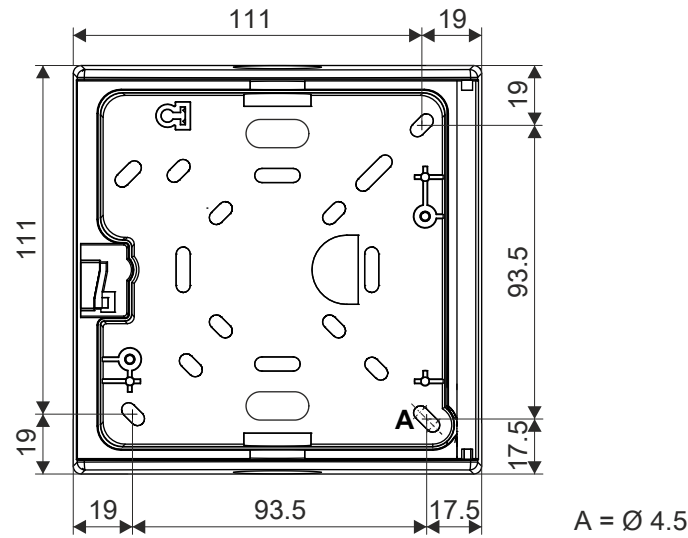

Manual call points FDM223H and FDM224H, housing FDMH292-R

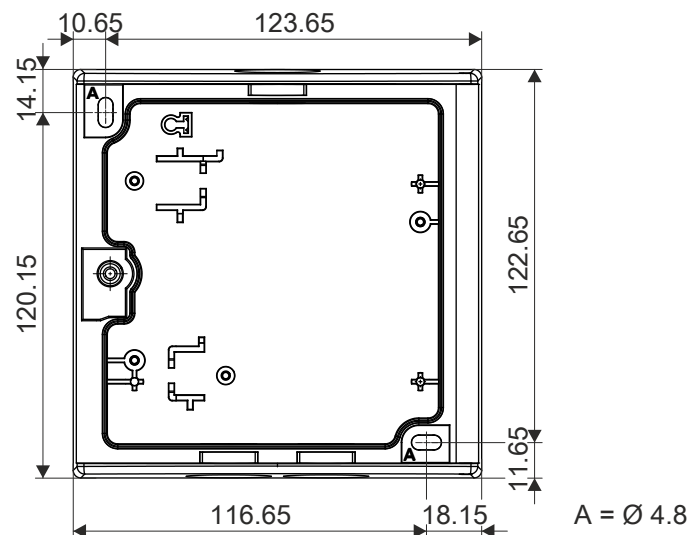

8.4 Environmental compatibility and disposal

	<p>This equipment is manufactured using materials and procedures which comply with current environmental protection standards as best as possible. More specifically, the following measures have been undertaken:</p> <ul style="list-style-type: none"> • Use of reusable materials • Use of halogen-free plastics • Electronic parts and synthetic materials can be separated <p>Larger plastic parts are labeled according to ISO 11469 and ISO 1043. The plastics can be separated and recycled on this basis.</p>
	<p>The device is considered an electronic device for disposal in accordance with the European Guidelines and may not be disposed of as domestic garbage.</p> <ul style="list-style-type: none"> • Dispose of the device through channels provided for this purpose. • Comply with all local and currently applicable laws and regulations.

Index

- A**
- Alarm indicator 19, 38
 - Application area
 - Ambient conditions 26
 - Approvals 47
- C**
- CE marking 47
 - Collective behavior
 - Degraded mode operation 21
 - Compatibility 26
 - Compatibility with control panels 26
 - Connection diagram 31
 - Connections
 - Spring clips 18
 - Control panel 38
 - Status query 44
- D**
- Danger levels
 - Signals transmitted to the control panel 19
 - Degraded mode operation
 - Collective behavior 21
 - Fire control panel failure 21
 - Detector exchanger and tester FDUD292
 - MC link 20, 44
 - Disposal 51
 - Download center
 - URL 7
- E**
- Environmental compatibility 51
 - Environmental influences 26
 - ES
 - Product version 15
 - EU directives 47
- F**
- Fire control panel failure
 - Degraded mode operation 21
- I**
- Impact
 - Chemicals 26
 - Moisture 26
 - Temperature 26
 - Installation in wet areas 29, 30
 - Intelligent detector tester FDUD293
 - MC link 20, 44
 - Intended use 5
 - Interface
 - MC link 44
 - Internal alarm indicator 19, 38
- L**
- Line separator
 - Function 19
 - List of compatibility 7, 21, 26
- M**
- Maintenance intervals 44
 - Manual call point
 - Test mode 19
 - MC link 44
 - Detector exchanger and tester FDUD292.. 20, 44
 - Intelligent detector tester FDUD293 20, 44
 - Proximity interface 20
- P**
- Packaging label
 - Product version 15
 - Product label
 - Product version 15
 - Proximity interface
 - MC link 20
- R**
- Recess-mounted cable entry 27
 - Recycling 51
 - Resetting after an alarm 43
 - Restoring to a state of operational readiness... 43



S

Sealing

DMZ1197-AD	32
FDMP223	34

Short-circuit

Line separator	19
----------------------	----

Signals transmitted to the control panel

Danger levels	19
---------------------	----

Spring clips

Connections	18
-------------------	----

Standards

49

Status query

Control panel	44
---------------------	----

Surface-mounted cable entry

27

T

Test mode

Manual call point	19
-------------------------	----

Type plate

Product version	15
-----------------------	----

Issued by
Siemens Switzerland Ltd
Smart Infrastructure
Global Headquarters
Theilerstrasse 1a
CH-6300 Zug
+41 58 724 2424
www.siemens.com/buildingtechnologies

© Siemens Switzerland Ltd, 2004
Technical specifications and availability subject to change without notice.