



cert. N.991k



0051  
16  
0051-CPR-1863

EN 54-2  
EN 54-4  
EN 54-21  
EN 12094-1



## Previdiia216

### Fire detection control panel

## PREVIDIA|MAX



**Previdiia216** is a modular system for the construction of fire detection and extinguishant systems (max. 24 channels).

This upgradeable system allows the configuration of a custom-built modular installation which can be easily expanded to meet growing requirements. The Previdiia Max control panels can have one or more cabinets (up to 4) assembled as a single control panel capable of managing up to 32 **IFM** units (loop modules, I/O modules, fire-extinction modules, etc.), and 8 **FPM** frontplate modules (back-up CPUs, LED modules, etc.).

Thanks to its functional modules and the help of special installation kits, this fire-detection control panel easily adapts to all types of environments and installations by allowing the creation tailored configurations perfect for every application. The IFM modules are hot swap modules that connect directly to the CAN DRIVE bar, therefore, can be added or replaced without switching the system off. As a result of this, the Previdiia Max system allows you to carry out quick and extremely safe replacements without interrupting service.

The **IFM2L** loop modules are equipped with the INIM ELECTRONICS in-house developed technology, "power up boosters", which allows the operating voltage of each loop to be set in accordance with requirements.

Thanks to a distributed-intelligence structure which uses a microprocessor inside each module, redundant microprocessors in the main unit and the possibility of having a backup CPU, Previdiia Max guarantees unmatched reliability. The security of the system is no longer entrusted to a single processing unit but to a group of interconnected CPUs which operate in synergy to provide the fastest and most effective response. This means that the control panel is certified to manage more than the 512 fire-alarm points contemplated in EN54 part 2.

As contemplated in EN54 part 2, the Previdiia Max control panel is capable of managing GAS detection directly through the loop. This is achieved through specific interfacing boards, I/O or 4-20mA modules and by assigning a different display mode and priority from fire alarms.

Thanks to its network architecture, Previdiia Max allows the realization of hybrid systems based on connections using bights, fiber optics and TCP-IP networks capable of overcoming all barriers and of reaching unprecedented cover. Each cluster of control panels interconnected through a **Hornet+** network can support up to 48 control panels, and up to 20 clusters can be connected through a TCP/IP network. Each cluster may consist of either a Hornet+ network, a control panel connected in TCP/IP or a repeat panel connected in TCP/IP.

Previdiia Max, as a result of intensive use of technologies such as emails, web-server, TCP/IP connections, GSM telephone communications, and concepts such as graphic maps and IP camera video-verification of alarms, provides you with a system that is continuously under control and always at hand, this greatly reduces response times in moments of danger and also lowers the false alarm rate considerably.

It is possible to connect lighting and emergency lights from the HARPER range directly to the Previdiia Max control panel loop and by so doing create a system with innovative functions for the supervision and periodic maintenance of the system.

Previdiia Max is capable of performing all the tests required by the applicable laws in force relating to the periodic review and, by means of programming software, can generate all the documentation required by current regulations.

# Previdia216

## HARDWARE FEATURES

---

- 7" touch screen, 65000 colours
- Emergency backup CPU
- 2 loops expandable to 16 (using IFM2L module)
- Certified LPCB CPR EN54 pt2 for the management of 512 fire detection points
- Certified LPCB CPR EN54 pt4
- Certified EN54 pt21 over PSTN, GSM and TCP-IP channels
- Certified EN12094-1 (fire extinguishing systems) up to 24 channels
- 1 Ethernet port for configuration via PC and TCP/IP connection for programming
- 1 RS232 port for configuration via PC and firmware upgrade
- 1 RS485 port for FPMCPU repeater (max. 14)
- 1 mini USB Port for configuration via PC
- 1 MODBUS RTU port
- 1 microSD card holder
- 2 CAN BUS ports
- 1 voltage-free relay 5A 30Vdc
- 1 programmable supervised alarm output 1.5A @27.V
- 1 output for external power 1.5A @27.6V
- Multi-processor hardware architecture
- Dedicated microprocessor for each module
- Scandinavian key for level 2 access
- Signalling LED and multiple-alarm scroll button
- 6 status LEDs
- 6 LED and function buttons
- Speaker
- Power supply voltage: 230 / 115 V~ (+10% -15%) 50/60 Hz
- Maximum current draw from mains: 1.1A @230V, 2A @115V
- Maximum available current: 5.2A
- Battery charger: 1.2A
- 1 CAN DRIVE bar for the connection of internal IFM modules (max 8)
- Battery housing for 2 batteries max. 24Ah@12V
- Dimensions: 433 x 563 x 187 mm (PRCAB)
- 19" rack mount (via PRCABRK)
- Possibility to connect up to 4 cabinets together
- Weight: 10Kg (PRACAB)
- Protection grade: IP 30

## FUNCTIONS AND SOFTWARE FEATURES

---

- Manages reserve FPMCPU unit configured as backup unit, 100% redundancy concept
- OpenLoop Technology
- LoopMap Technology
- Versa++ Technology
- Manages graphic maps
- Manages Modbus TCP protocol
- Manages Modbus RTU protocol
- IP camera video-verification of alarms (through IFMLAN)
- Manages BACNET IP protocol (through IFMLAN)
- Manages ESPA 444 protocol (through IFMLAN)
- Manages SIA-IP protocol (through IFMLAN)
- Manages voice evacuation systems via TCP-IP or RS232/485 (through IFMLAN)
- Manages up to 32 internal modules
- Manages up to 8 FPM frontplate modules
- Manages up to 4 internal power supplies (IFM24160) and 4 battery packs
- Manages up to 24 fire-extinguishing channels (through IFMEXT)
- PSTN GSM connections (through IFMDIAL)
- Possibility to send up to 100 SMS messages (through IFMDIAL)
- Possibility to send up to 100 voice messages for a maximum of 15 minutes (through IFMDIAL)
- Manages digital protocols over PSTN and GSM (through IFMDIAL)
- Generates periodic reviews for the lighting and emergency lights in compliance with the regulations in force
- Manages up to 48 panels in Hornet+ network via the IFMNET module
- Up to 20 clusters connectible in TCP/IP
- 2 or 4 wire loop connection
- Up to 240 devices per loop (depending on the selected protocol)
- Control equations for activations with logical operators (And, Or, Not, Xor, etc.).
- 1000 software zones per control panel
- 1000 logic groups per control panel
- 500 trigger activations for each control panel
- 100 actions
- 240 logic group shareable in Hornet+ network or cluster
- WalkTest function
- Up to 2000 event memory capacity
- Self-enrolling (for loop devices)
- Self-addressing function for loop devices
- Manages 4 access levels in accordance with EN54-pt2
- Code or key access to Level 2 functions (EN54 compliant)
- 4 password levels
- 100 user codes
- User-friendly programming software (runs under Windows)



EN 54-2  
EN 54-4  
EN 54-21  
EN 12094-1

# PREVIDIA<sub>I</sub>MAX

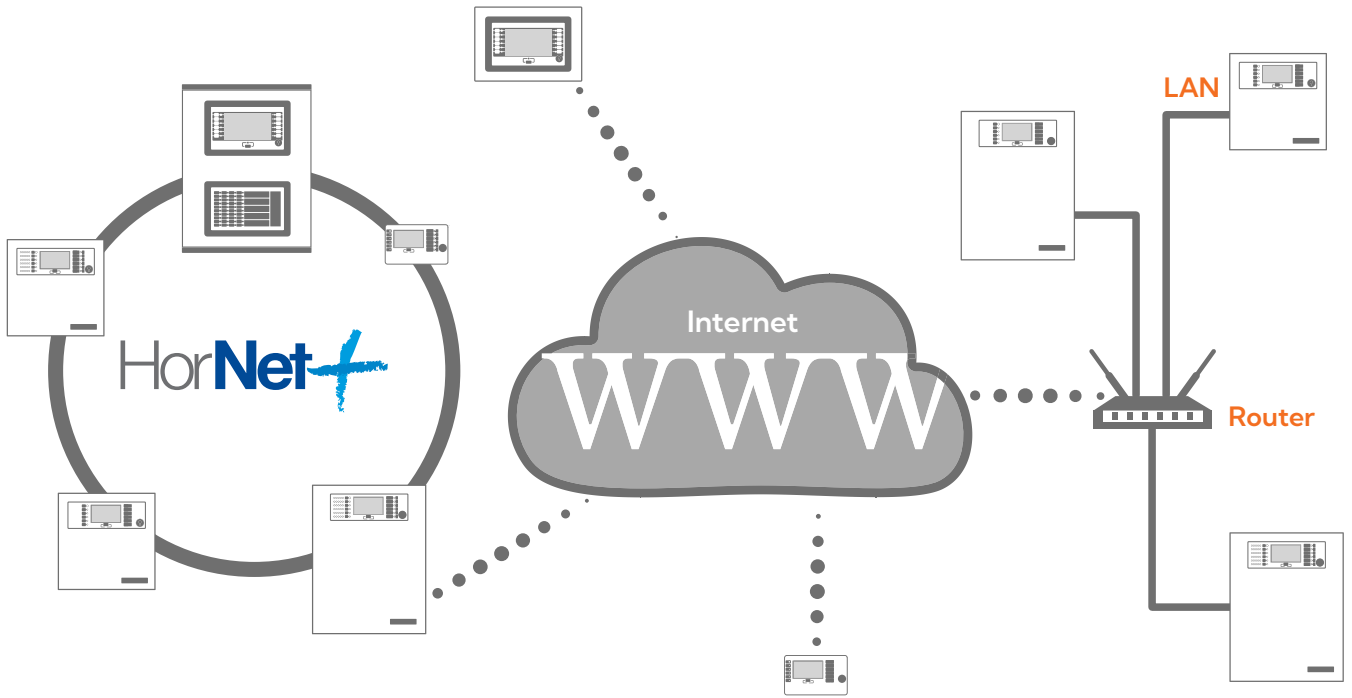

## DIMENSIONS

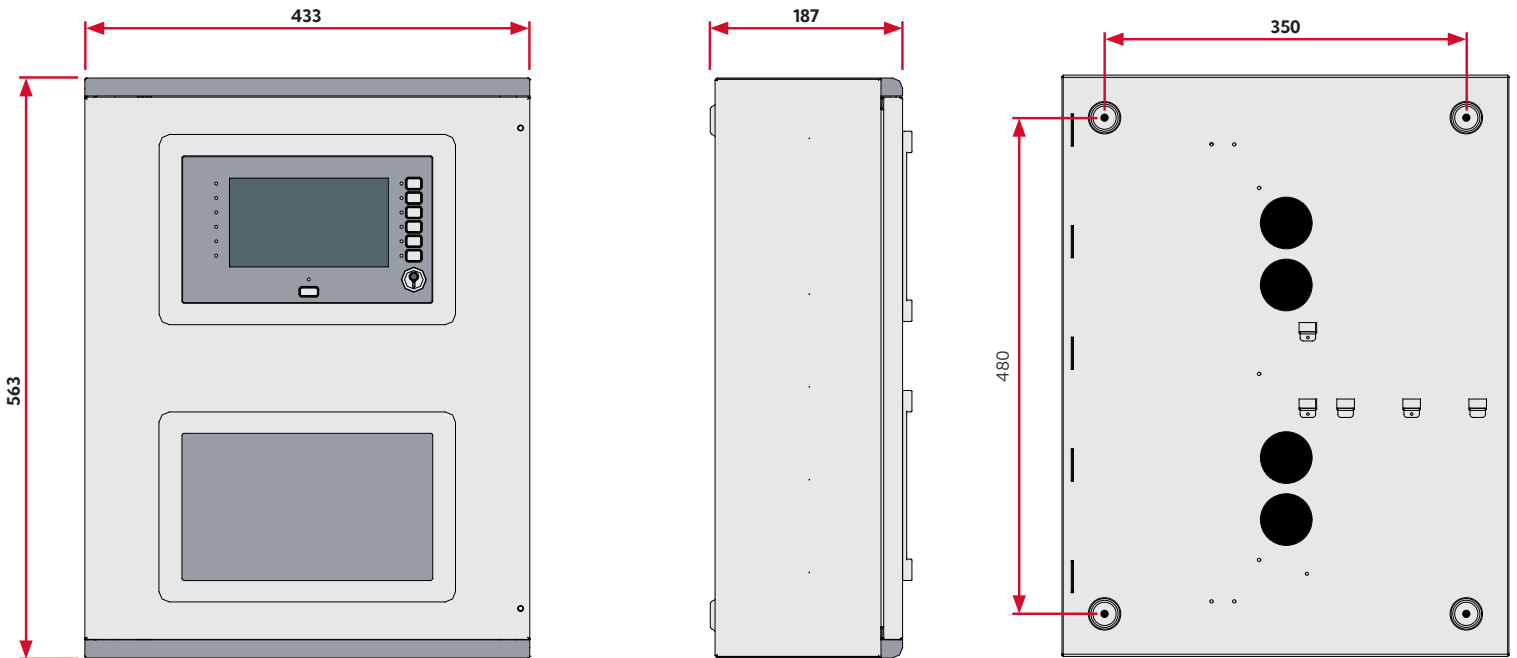

### PACKAGE CONTENTS

---

Package dimensions: 500 x 620 x 250 mm

Weight including packaging: 12.5kg

### ORDER CODES

---

#### Previdia Max control panel (standard model)

**Previdia216** Analog addressable control panel with 2 loops expandable to 16

**Previdia216R** The same as Previdia216 but comes in a red cabinet

#### FPM front-plate modules

**FPMNUL** Plastic support with no functions (max. 7)

**FPMLED** Signalling module with 50 programmable LEDs

**FPMLEDPRN** Signalling module with 50 programmable LEDs complete with thermal printer (max. 1)

**FPMEXT** Module for signals relating to extinction channels (max. 5)

**FPMCPU** CPU module which can be programmed as a repeater, reserve CPU or main CPU (max. 1 as backup)

#### IFM internal modules

**IFM24160** Power-supply module (max. 4)

**IFM2L** 2-loops module (max. 8)

**IFM4R** 4-relays module (max. 16)

**IFM4IO** Module with 4 programmable terminals (max. 16)

**IFMDIAL** Communication module over PSTN or GSM line (max. 1)

**IFM16IO** Module with 16 inputs/outputs (max. 4)

**IFMNET** Module for the connection of control panels in a Hornet+ network (max. 1)

**IFMLAN** Module for the management of advanced TCP-IP services (max. 1)

**IFMEXT** Gas extinction-system management module (max. 24)

#### Cabinets

**PRCAB** Add-on cabinet

**PRCABR** Add-on cabinet in red

#### Accessories

**PRCABSP** Spacer bracket for mounting the cabinet to wall

**PRCABSPR** As per item PRCABSP but in red

**PRCABRK** Bracket for mounting the cabinet to a 19' rack

**PRREP** Enclosure for mounting FPMCPU module as remote repeater

**GSM-ANT100B** High performance GSM antenna, white

**GSM-ANT200N** GSM antenna with installation bracket and 3mt cable, black

**PRBAC** BACNet IP license (requires IFMLAN)