

SOUNDER BASE

VDOT-S6 BASE



▪ **Description**

VDOT-S6 Base is a detector base with sounder, which is individually or collectively controlled by a control panel using addressable system. The detector base has 4 sound patterns which are continuous, march, ANSI 3 temporal and 4 temporal patterns. These patterns which are used in and around buildings can be selected by a control panel. The sound pressure level at 10 feet from the base is over 85 dB. Up to 127 bases can be connected to a loop of the control panel. The base is designed to be mounted to 3-1/2" octagonal, 4" octagonal or 4" square electrical box.

▪ **Compatible Detector Models**

Models	Description
VDOT-PY	Addressable Photoelectric Smoke Detector
VDOT-PYH	Addressable Multisensory Detector
VDOT-H2	Addressable Heat Detector
VDOT-DPH	Addressable Dual Optical / Heat Detector

▪ **Features**

- UL Listed Base.
- Compatible to Velocity's UL Listed detectors.
- Provides 4 sound patterns (continuous, march, ANSI 3 temporal, ANSI 4 temporal).
- Over 85 dB at 10 feet away.
- Address programmed by VDOT-AD2 programmer.
- Contains a locking screw for tamper protection.
- Reduces wiring cost.

▪ **Dimensions**

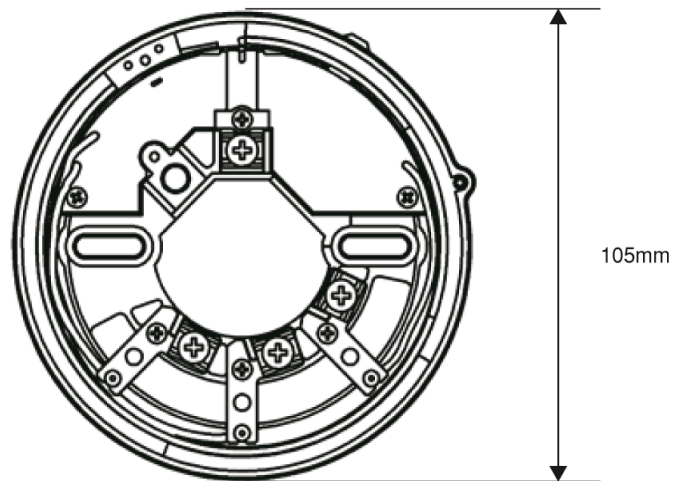

Installation Diagrams

Analog Addressable Wiring

When connected to analog addressable detectors such as VDOT-PY, VDOT-PYH, VDOT-H2, VDOT-DPH, etc.

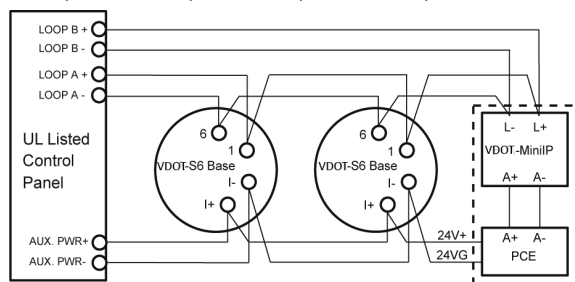

If the AUX. supply circuit needs to be monitored to detect short circuit or open circuit, connect PCE (End-of-line supervision module) to the end of the AUX. supply circuit and VDOT-MiniIP to SLC.

Terminals

VDOT-S6 Base is supplied with 5 terminals (including 1 unused) as follows:

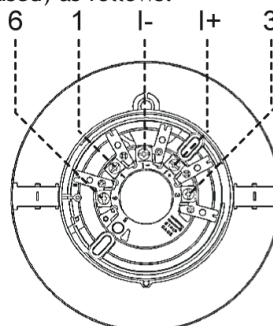

Terminals

- Terminal 6 = SLC -
- Terminal 1 = SLC +
- Terminal I- = AUX -
- Terminal I+ = AUX +
- Terminal 3 = UNUSED

Mounting

VDOT-S6 Base can be mounted to 4" square, 4" octagonal, or 3-1/2" octagonal electrical box.

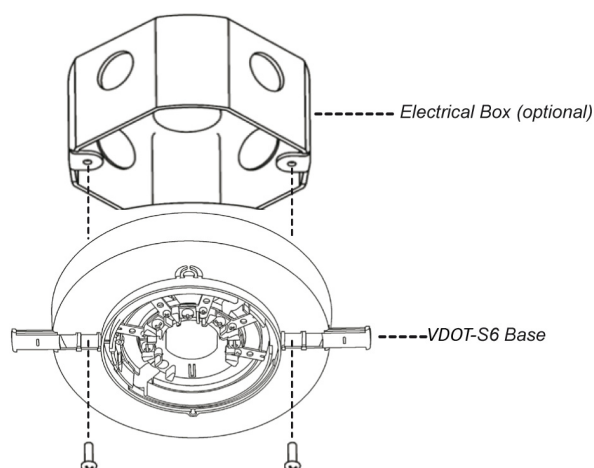

Locking Screw

VDOT-S6 Base contains a locking screw to avoid unauthorised removal of detectors.

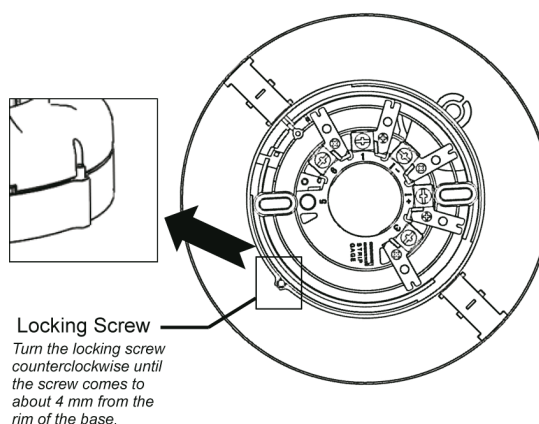

Specification

Specifications	VDOT-S6 Base
SLC Applied Voltage	Rated Range 20 VDC to 38 VDC
AUX. Supply Voltage	Rated Range 16 VDC to 33 VDC
SLC Current Consumption	Standby: 0.5 mA Alarm: 1.4 mA
AUX Supply Current Consumption	Standby: 0.5 mA Alarm: 20 mA
Sound Pressure Level	≥ 85 dB @ 10 Feet Away
Maximum Quantity Per Loop	127 units
Operating Temperature	-10 °C to +55 °C (14 °F to 131 °F)
Storage Temperature	-20 °C to +60 °C (-4 °F to 140 °F)
Relative Humidity	≤ RH 95 % Non-Condensing
Environment	Indoor, dry use only
Terminal	AWG12-20
Dimensions	φ160 mm x H 31 mm
Weight	170 g
Standard	UL268 and UL464

All specifications are subject to change without any notice.
For more information, contact with VELOCITY.



Zeta Alarms Limited
72-78 Morfa Road, Swansea
SA1 2EN
Tel: +44 1792 455 175 FAX: +44 1792 455 176

Distributed By