

300PSI NRS Flanged End Gate Valve

Model: Z45-300A

Resilient Wedge NRS Gate Valve – Flanged End

Technical Features

- Nominal Pressure: 300PSI
- Conforms: ANSI / AWWA C515 Standard
- Face to Face Standard : ASME B16.10
- Sizes: 2", 2½", 3", 4", 5", 6", 8", 10", 12"
- 2" FM only
- Flange Standard: ASME / ANSI B16.1 Class 125 or ASME / ANSI B16.42 Class 150 or BS EN1092-2 PN16 or GB / T9113.1
- Approvals: FM, UL, CUL, NSF / ANSI 61 & NSF / ANSI 372
- Maximum Working Pressure: 300PSI (Maximum Testing Pressure: 600 PSI) conforms to UL262, ULC / ORD C262-92 , FM 1120 / 1130
- Maximum Working Temperature: 80°C / 176°F
- Coating Details: Epoxy coated interior and exterior by Electrostatic Spray or Coating upon request
- NPT plug on body with 2 operating nuts
- Certified lead-free by NSF / ANSI 61 & NSF / ANSI 372 is available
- With and Without Post Flange are available

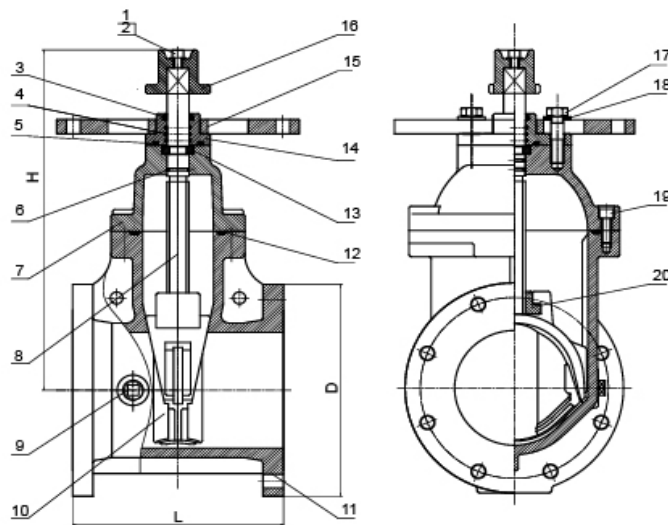

Dimensions

Size	DN	L	D	H
2"	50	178	152	265
2½"	65	190	178	292
3"	80	203	191	322
4"	100	229	229	342
5"	125	254	254	412
6"	150	267	279	448
8"	200	292	343	534
10"	250	330	406	635
12"	300	356	483	720

Valve Material List

NO.	Name	Material
1	Flat Washer	Steel 1045 or Stainless Steel 304
2	Hexagon Socket Screw	Steel 1045 or Stainless Steel 304
3	Sealing Ring	EPDM
4	O-ring	EPDM
5	Sealing Ring	EPDM
6	O-ring	EPDM
7	Bonnet	Ductile Iron
8	Stem	Stainless Steel 304 or Steel 1045
9	Plug	Stainless Steel 304 or Steel 1045
10	Disc	Ductile Iron +EPDM
11	Body	Ductile Iron
12	Sealing Ring	EPDM
13	Retaining Ring	C95400
14	Gland	Ductile Iron
15	Post Flange	Ductile Iron
16	Wrench Nut	Ductile Iron
17	Bolt	Stainless Steel 304 or Steel 1045
18	Washer	Stainless Steel 304 or Steel 1045
19	Hexagon Socket Screw	Steel 1045 or Stainless Steel 304
20	Stem Nut	CF8 or C95400